

**MANUFACTURED BY:**

Cy-Tech GmbH
 Happurger Str. 86
 90482 NUERNBERG | Germany
info@indoorcycling.com
www.indoorcycling.com
 Phone: +49(0)911 / 54 44 50

WATTRATE® TFT COMPUTER 2.0

PART NO: 320-00-00016-01



CAUTION!

READ ALL PRECAUTIONS AND INSTRUCTIONS IN THIS MANUAL BEFORE YOU START USING THIS EQUIPMENT. PLEASE KEEP THIS MANUAL FOR FUTURE REFERENCE. IMPROPER ASSEMBLY, USE OR MAINTENANCE CAN VOID THE WARRANTY TERMS.

ADDITIONAL LANGUAGES AVAILABLE FOR DOWNLOAD AT WWW.INDOORCYCLING.COM

Version 2.0 WattRate® TFT 2.0 | Copyright by Cy-Tech GmbH 2023 | www.indoorcycling.com



ATTENTION



EN

To download the owners manual in your language, visit the support section at: www.teamicg.com



FI

Lataa omistajan käsikirja omalla kielelläsi-ohjeosiosta sivustolta: www.teamicg.com



DE

Um das Handbuch in Ihrer Sprache herunterzuladen, besuchen Sie bitte den Support Bereich auf unserer Webseite unter www.teamicg.com



NO

Du kan laste ned bruksanvisningen på ditt eget språk ved å gå til støttesiden på: www.teamicg.com



FR

Pour télécharger le manuel d'utilisation dans votre langue, consultez la section Assistance sur: www.teamicg.com



SE

Du kan hämta bruksanvisningen på ditt språk under-support på www.teamicg.com



IT

Per scaricare il manuale nella vostra lingua, visitate la sezione del supporto per su: www.teamicg.com



PL

Aby pobrać podręcznik użytkownika w swoim języku, należy wejść na zakładkę support na stronie: www.teamicg.com



NL

Ga om de gebruiksaanwijzing in uw taal te downloaden naar het supportgedeelte onder: www.teamicg.com



TR

Kullanıcı kılavuzunu kendi dilinizde indirmek için www.teamicg.com sayfasının deste bölümünü ziyaret edebilirsiniz



ES

Para descargarse el manual de usuario en su idioma, por favor acceda a la sección de soporte técnico de la bici en: www.teamicg.com



CN

在IC7的客户服务网站，您可以下载各种语言的用户手册 www.teamicg.com



PT

Para transferir o manual de utilizador no seu idioma, visite a secção „Suporte” da em: www.teamicg.com



JP

オーナーズマニュアルの各言語版は、以下サイトの サポートページからダウンロードいただけます。 www.teamicg.com



DK

Besøg supportafsnittet www.teamicg.com for at downloade brugermanualen på dit sprog



KR

지원 센터(www.teamicg.com)에서 해당 언어 버전의 사용설명서를 다운로드할 수 있습니다..

CONTENTS

IMPORTANT PRECAUTIONS	P.4
ASSEMBLY	P. 5
SETUP	P. 6
BASICS	P. 7 - 8
DEFINITION TERMS & ABBREVIATIONS	P. 9
COACH BY COLOR® TRAINING ZONES	P. 10
MEDICAL DISCLAIMER	P. 11
CONNECTIVITY	P. 12
TRAINING MODES/PAUSE MODE	P. 13
LAP BUTTON/DISPLAY HEADER	P. 14
QUICK-START MODE	P.15
POWER TRAINING	P.16 - 18
HEART RATE TRAINING	P. 19 - 21
FTP RAMP TEST	P. 22
FTP 5 MINUTE TEST	P. 23
FTP 20 MINUTE TEST	P. 24
DIRECT FTP ENTRY	P.25
SETTINGS	P. 26
QUICK SETUP / SYSTEM	P. 27
CONNECT / COACH BY COLOR	P. 28
KEY FUNCTIONS	P. 29
MAXIMUM DISPLAY RANGES	P. 30
EU DECLARATION OF CONFORMITY	P.30
FCC COMPLIANCE	P. 32
DISPOSAL ELECTRIC WASTE	P. 33

IMPORTANT PRECAUTIONS

WARNING!

To reduce the risk of serious injury due to improper use, carefully read and adhere to the safety precautions and information before using the device. Please also take note of the precautions in the Indoor Cycle Manual, on which this computer is to be used.

1. It is the responsibility of the owner to ensure that all users are informed of all warnings and precautions for proper use of the equipment. You are authorized to use the bike independently after being successfully briefed by a qualified trainer or instructor.
2. Keep the indoor cycle indoors, away from moisture and dust. Do not place the indoor cycle outdoors in a garage or covered patio or near water or pools. Operating temperature of the indoor cycle has to be between 15°C ~ 40°C Celsius (59°F~104°F) at a maximum humidity of 65%.
3. **WARNING:** The training equipment can be used by children aged from 14 years and above and persons with lack of experience and knowledge if they have been given supervision or instruction concerning use of the appliance in a safe way and understand the hazards involved. Children under 14 years of age and Persons with reduced physical, sensory or mental capabilities are prohibited from using the training equipment.
4. All data shown on the display, especially the Watt values, serve merely as information and to help guide training. Only exercise within your physical limitations.
5. If you feel physical discomfort or dizziness, stop training and consult a physician. If the user requires medication that has effect on their performance capabilities and/or cardiovascular system, it is imperative that they consult a doctor in order to adjust the personal entries accordingly.
6. Heart rate monitoring systems may be inaccurate. Over exercising may result in serious injury or death. If you feel faint stop exertion immediately !

CAUTION

If you have pre-existing health problems or a disability, it is recommended that you consult your physician, in order to find the training method which is best suited to you. Incorrect or extensive training can result in serious health injuries. The manufacturer expressly assumes no responsibility for health risks, personal injury, property damage or consequential damages sustained by or through the use of this device, unless it is a case of consequential damage which can be traced back to faulty material and/or manufacturing, and which come under the responsibility of the manufacturer.

CONTENTS



- 1 pcs. TFT 2.0 Console
- 2 pcs. Spacer
- 1 pcs. Bolt
- 1 pcs. Seal

ASSEMBLY

1.

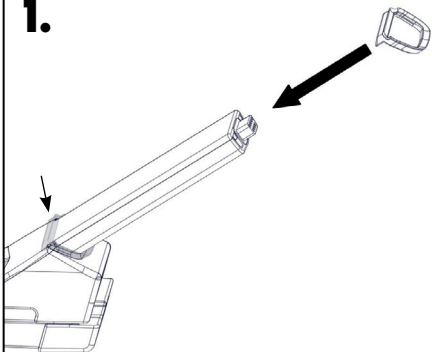

SLIDE THE SEAL DOWN THE COMPUTER BRACKET

2.

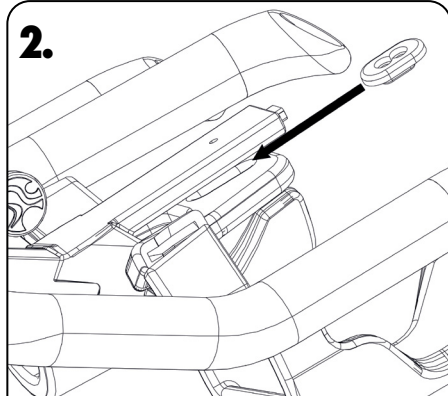

INSERT THE SPACER BETWEEN THE COMPUTER BRACKET AND THE HANDLEBAR. THE SPACER MUST FIT IN THE GROOVE OF THE HANDLEBAR.

3.

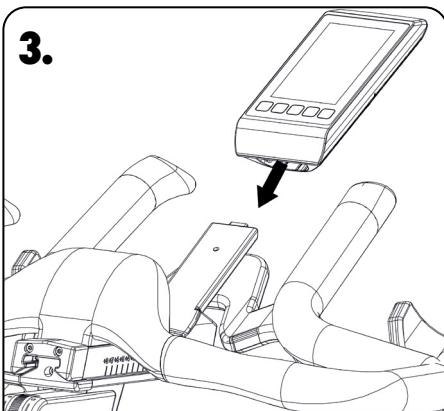

SLIDE THE CONSOLE ON THE BRACKET

4.

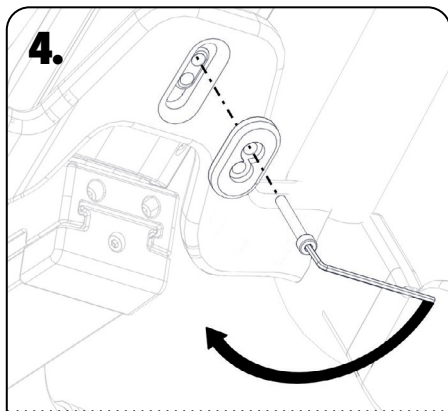

MOUNT THE 2ND SPACER TO THE OUTSIDE OF THE HANDLEBAR WITH A 3MM ALLEN KEY.

SETUP

Once pedaled, the console will automatically start and guide you through the general settings when turned on for the first time. These settings can be changed at a later point in time in the settings menu. Select according to your preferences.

SELECT BIKE: IC6/IC7/IC8

LANGUAGE: Selection menu

WEIGHT UNITS: KG/LBS

DISTANCE UNITS: KM/MILES

SELECTING COLOR MODE

Enables the user to view the power or heart rate training Coach by Color screen in either of 3 ways.

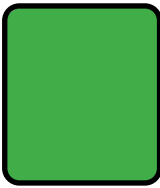

FULL SCREEN

Full Screen -
Training Zone
Color is displayed
over the entire
screen

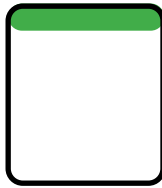

BANNER

Training Zone
Color is displayed
as a small bar at
the top of the
screen

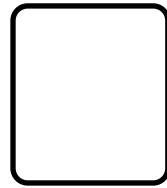

OFF

Training Zone
Color is NOT
displayed

FRONT LED

Default: ON. By turning the light off, the trainer receives no color indication via the front LED during a Coach By Color course, limiting the possibilities for training guidance during a class. The background lighting of the display remains unaffected by this setting. ICG suggests leaving this setting on.

ICG APP ADVERT

When ON, a QR code with a download link will be displayed on the screen during startup.

BIKE ID

During installation each bike must be given its own unique bike identification number. The identification number is required for use with ICG Connect and App pairing. Hold the arrow button to quickly increase/decrease value in increments of 5.

BASICS

**5 COLOR FRONT LED LIGHTING
AND FULL COLOR TFT DISPLAY FOR
COACH BY COLOR TRAINING**

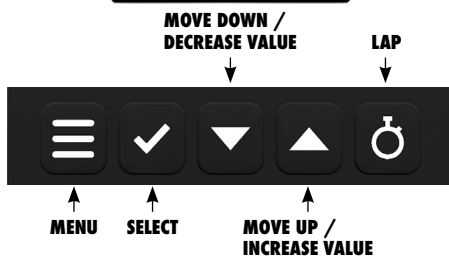
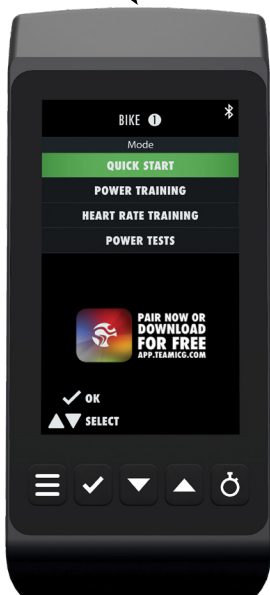

MENU:

Go back to previous selection or exit menu.

SELECT:

Confirm selection.

UP / DOWN ARROWS:

Use the arrow buttons to navigate the computer menus and training displays.

LAP:

Start and Stop Laps during a training.

BASICS

SWITCH ON

Until the flywheel is moved, the computer is in deep sleep state. To switch the computer on, turn the pedals one complete revolution. After approx. 5 seconds, the computer will boot and the display will be turned on.

If the computer does not switch on after one complete revolution of the pedals, the battery is empty. Charge the battery by pedalling the bike at a cadence of >50 RPM. During the charging process, the computer will turn on and the bike can be used.

SWITCH OFF

If the flywheel is not moved for 2 minutes, the computer switches itself automatically off. The switch off time is extended by 2 minutes if a console button is pushed or 5 min. if you enter pause mode.

INTEGRATED ENERGY MANAGEMENT

For low pedaling frequencies under 50 RPM, the energy is supplied by a built-in LiPo accumulator. When the cadence exceeds around 50 RPM, enough energy is generated to supply the system with power and if necessary charge the LiPo battery.

BATTERY STATUS DISPLAY

If the charge capacity of the battery has almost been depleted, a flashing battery symbol is shown on the top of the display.

If you pedal with a cadence of > 50 RPM for several minutes, the flashing battery symbol disappears. It is then possible to operate the computer in battery mode for several minutes, during which user settings can be entered.

If the battery status display is active and the cadence reduces or if you brake or stop pedaling for a short period of time, the Coach by Color LED lighting will switch off, to prevent draining the battery.

Please note that as long as the battery status display is active, the computer may be switched off suddenly even if a key is being pressed.

ACCURACY

The average displayed values on the console are accurate within $\pm 10\%$ at 50 - 120 RPMs at a power of 50 - 900 watts.

DEFINITION TERMS & ABBREVIATIONS

COACH BY COLOR® (CBC) Power-orientated (WattRate®) or heart rate oriented training guidance based on individual user settings by training zones depicted in color.

WATT Unit of power which is calculated based on the time during which work is done. The calculation is carried out using the formula: Power (measured in Watts) = force x speed.

WATTRATE® Direct measurement of the power rendered by the cyclist in real time.

FTP Functional Threshold Power®, also termed FTP Index. Power delivered in Watts to the functional threshold power (FTP = 100% corresponds to the aerobic/anaerobic power threshold)

FTP% Functional Threshold Power® in per cent. Information on the current power with respect to the FTP value in per cent $FTP\% = (\text{current power in Watts} / \text{FTP}) \times 100$

RPM Revolutions Per Minute, Cadence, pedaling frequency (PFQ), Revolutions Per Minute (R/min)

HR Heart Rate

HR MAX % Information on the current heart rate with respect to the maximum heart rate in percent $HR\ MAX\ \% = (\text{current HR} / \text{HR max}) \times 100$

BPM

Beats per Minute

In this manual, this relates to the heart rate of the user.

LIPO LiPo = Lithium-Polymer battery. A rechargeable battery with a high energy density

TSS® Training Stress Score allows an endurance athlete the ability to quantify their workouts based on their relative intensity, duration, and frequency of workouts.

IF® Intensity factor is an indication of how hard or difficult a ride was in relation to your overall fitness

EFFORT POINTS are calculated for your workout depending on the amount of time you ride in the individual training zones. They are displayed in the upper left hand corner of the LCD display during a power or heart rate training and the accumulated effort points may also be displayed during Connect workouts.

GIVEN POINTS FOR 1 MINUTE OF RIDING IN EACH ZONE:

1 EFFORT POINT	0-55% of your FTP / 50 – 59% of your HRM
2 EFFORT POINTS	56-75% of your FTP / 60 - 69% of your HRM
3 EFFORT POINTS	76-90% of your FTP / 70 – 79% of your HRM
4 EFFORT POINTS	91-105% of your FTP / 80 – 89% of your HRM
5 EFFORT POINTS	106-120% of your FTP / 90 - 95% of your HRM
5.5 EFFORT POINTS	121- +150% of your FTP / 96 – 100% of your HRM

COACH BY COLOR® TRAINING ZONES

COACH BY COLOR® TRAINING CONCEPT

The 5 color zones used by ICG (white, blue, green, yellow, red) can be used based on the power (watts) of every user of the bike. The training zones are based on the current power in relation to the individual FTP (Functional Threshold Power®) value. The same principle of calculating training zones applies when using the maximum heart rate (HR max) and an analogue POLAR®, Bluetooth® or ANT+® compatible chest belt. As soon as the max HR or the individual FTP value are known, the personal training zones can be worked out accordingly and in doing so the intensity can be displayed by the colors during the training session based on the heart rate or watts.





Using the FTP power tests integrated in to the computer; 5 minute, 20 minute and Ramp Test, the user has the option to monitor both current performance and progress.

CAUTION

The power tests should only be carried out under the supervision and guidance of a qualified Instructor or Trainer.

In both Power Training and Heart Rate Training the user has the option to turn off the Coach By Color® Training Guidance by selecting Color Mode OFF if he/she wishes.

COACH BY COLOR® – 5 ZONES

5 Colored Zones	Powered % FTP	Time	% HR ^{Max}	Load
Active Recovery	< 55 %	Infinity	< 60 %	Very Light
Endurance	56 – 75 %	3 – 8 hours	61 – 70 %	Light
 Ignite	67 – 75 %		66 – 70 %	Light/Moderate
Tempo	76 – 90 %	3 – 8 hours	71 – 80 %	Moderate
 Heat	85 – 95 %		78 – 85 %	Moderate/Hard
Lactate Threshold	91 – 105 %	10 – 60 min	81 – 90 %	Hard
V _{O2} ^{Max}	> 105 %	1 – 8 min	> 90 %	Hard/Maximal
 On Fire/Anaerobic Capacity	121 – 150 %	1 – 5 min	92 – 94 %	Maximal
 Burn/Neuromuscular Power	> 150 %	5 – 10 sec	95 – 100 %	Maximal

MEDICAL DISCLAIMER

CAUTION

The division of the training zones for power or heart rate oriented training is based on an average person's performance. The zones may sometimes vary dramatically depending on the nature of the training, the state of your health (e.g. whether you are taking any medications) and your physical capabilities. It is recommended to always work out sensible training parameters for your own personal training under medical supervision, and to plan your personal training based on this data.

WARNING

- Do not exercise beyond your ability.
- If you feel physical discomfort or dizziness, stop training and consult a physician.
- Color zones are for guidance only.
- If the user requires medication that has an effect on their performance capabilities and/or cardiovascular system, it is imperative that they consult a doctor in order to adjust the personal entries accordingly.

CONNECTIVITY*

CHEST BELTS		
BLE compatible heart rate sensors	Polar compatible heart rate sensors at 5.5 kHz (coded sensors recommended)	ANT+ compatible heart rate monitors.
ICG APP**		
You can connect the ICG App to the bike console with your mobile device via Bluetooth (Bluetooth must be manually activated in your mobile device). The app can transfer your personal data such as gender, age, weight and FTP value automatically to your bike console before workouts and record your workouts for personal review.		
BROADCAST DATA**		
Hardware or apps that support ANT+ or BLE technology can in principle receive the provided data.		
	ANT+	BLE
HEART RATE	YES	NO
CADENCE	YES	YES
POWER	YES	YES
* Some features may depend on the installed software version of your WattRate® TFT Computer ** Your mobile device and apps must support the features and they must be enabled before use.		

PAIRING THE ICG APP TO THE CONSOLE

Start the console on the bike until you see the training selection screen. Start the app on your mobile device and follow the instructions.

IMPORTANT!

All compatible apps must be paired with the TFT 2.0 in the home screen or in the activated pause mode.

TRAINING MODES

DIRECT FTP ENTRY

Power training with direct FTP value entry. Option must be activated in Settings/System/Direct FTP Entry

QUICK START:

Quick start, without entering any user settings.

POWER TRAINING:

Detailed entry of user settings including index values (for FTP and max HR) as well as optional connection to a compatible chest belt. Training zone guidance is based on watts (power)

HEART RATE TRAINING:

Requires a compatible chest belt, detailed entry of user settings and index values (for FTP and max HR) Training zone guidance is based on heart rate

POWER TESTS:

Determine your FTP value with one of the FTP tests.

PAUSE MODE

The pause mode can be used to briefly stop and continue your training without losing workout data. There are 2 different methods in which the pause mode can be activated:



↑
PAUSE

1. Push the tick or menu button during your workout to stop your workout. Push the tick button again to continue.
2. Stop pedaling to activate the pause mode. Your workout can be resumed by pedaling the bike. If adjustments were made to the computer during the pause, resume your training by pushing the tick button.

SUMMARY

When selected, an overview of the stats from your training session are displayed.

ADJUST FTP

Allow adjustment of FTP without ending the training session.

LAPS

View all lap distances and times from current workout

HR CONNECTION

Connect / disconnect to Heart Rate Chest belt.

RESTART WORKOUT

Begins a new workout with the entered user settings.

END WORKOUT

Ends workout ,resets user settings and deletes user data.

LAP BUTTON

During a Quick Start, Power or Heart Rate training, the lap function starts a timer and measures distance.

Start a lap by pushing the lap button. An icon that a lap was started will appear at the top of the screen. The distance traveled and a timer will be displayed in the bottom squares.

Once you have reached your targeted distance or time, push the lap button to stop the lap.

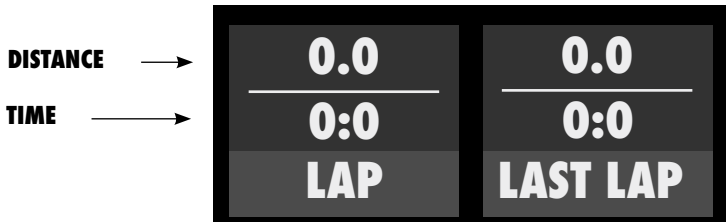
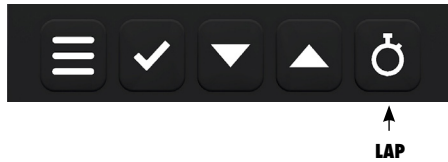

After the lap is completed, the last lap data will be displayed until the next lap is completed.

DISPLAY HEADER

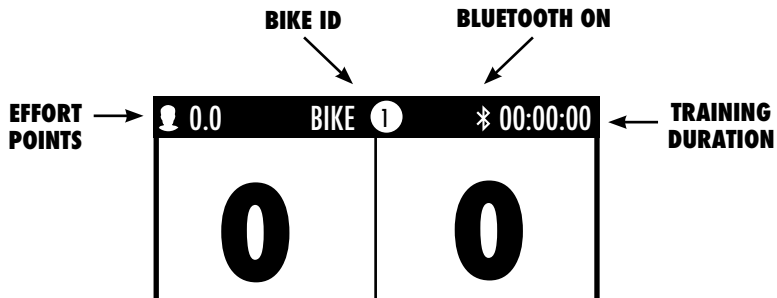

QUICK-START MODE

Select Quick Start Mode and begin training. The following information is displayed on the screen.

RPM Current cadence	LEVEL Resistance (0-100)
WATT Current power output	KCAL KCalories burned
MILES/KM Distance covered	MPH/KM Speed
LAP Current distance/ time	LAST LAP Distance/time

The Lap and Last Laps are displayed after at least one lap has been started and will automatically disappear 5 seconds after the lap has been stopped. It will repeat once another lap has been started.

POWER TRAINING

The Power Training mode enables you to enter additional user settings and to connect the computer to a compatible chest belt. In this mode, the individual threshold (FTP and max HR) can be precisely entered, or if not known, calculated based off the biometric data entered into the console. It is also possible to carry out the Coach By Color® training guidance based on power or heart rate.

WARNING!

- Systems for monitoring heart rate may not be completely accurate.
- Excessive exercise can cause severe damage to health and can even result in death.
- If you feel dizzy or weak, stop exercising immediately.
- This device is not intended to be used by persons (including children) with restricted physical sensory or mental capabilities or with a lack of experience and/or knowledge, unless they are supervised by someone responsible for their safety or have received instructions from this person on how to use the device (e.g. from a doctor, trainer, etc.).
- Children must be supervised at all times to ensure that they do not play with the equipment.
- An additional consent is provided by the user when the Medical Disclaimer is acknowledged by pressing the button at the beginning of the training session in Power Training or Heart Rate Training Mode.

CAUTION:

The calculated FTP values are intended as a guide but in order to receive precise values, we advise carrying out the FTP Power Test.

POWER TRAINING

FOLLOW THE STEP BY STEP DIRECTIONS CAREFULLY AS PROMPTED ON THE DISPLAY TO START A TRAINING SESSION.

The power training mode has 4 screens that display different information during training. Toggle between the screens by pressing the arrow buttons.



SCREEN 1

RPM Current cadence	LEVEL Resistance (0-100)
WATT Current power output	ZONE Current zone. Position in current zone.
LAP Distance /Time	LAST LAP Distance /Time

SCREEN 2

BPM Heart Rate	KCAL Calories burned
MILES/KM Distance	MPH/KMH Speed
WATT/KG Power/Weight ratio	WATT/HR Power/Heart Rate Ratio

The Lap and Last Laps are displayed after at least one lap has been started and will automatically disappear 5 seconds after the lap has been stopped and will repeat once another lap has been started.

POWER TRAINING

SCREEN 3

WATT AVG WATT MAX	BPM AVG BPM MAX
FTP %	MHR %
RPM AVG RPM MAX Cadence	MPH/KMH AVG MPH / KMH MAX Speed
WATT/KG AVG WATT/KG MAX Power	WATT/HR AVG WATT/HR MAX Power/Heartrate Average
LEVEL AVG/MAX Average/Max Level	TSS/ IF Training Stress Score / Intensity Factor

SCREEN 4

RED/ZONE 5 Time and % spent in zone	DISTANCE/KCAL Distance travelled and kCal in zone
YELLOW/ZONE 4 Time and % spent in zone	DISTANCE/KCAL Distance travelled and kCal in zone
GREEN/ZONE 3 Time and % spent in zone	DISTANCE/KCAL Distance travelled and kCal in zone
BLUE/ZONE 2 Time and % spent in zone	DISTANCE/KCAL Distance travelled and kCal in zone
WHITE/ZONE 1 Time and % spent in zone	DISTANCE/KCAL Distance travelled and kCal in zone

Dynamic overview of training zones and time.

The absolute time spent and percentage of the time in which you were training in each zone is displayed.

HEART RATE TRAINING

The Heart Rate Training mode enables you to enter additional user settings and to connect the computer to a compatible chest harness. In this mode, the individual threshold (FTP and max HR) can be precisely entered, or if not known calculated based off the biometric data entered into the console. It is also possible to carry out the Coach By Color® training guidance based on wattage or heart rate.

WARNING!

- Systems for monitoring heart rate may not be completely accurate.
- Excessive exercise can cause severe damage to health and can even result in death.
- If you feel dizzy or weak, stop exercising immediately.
- This device is not intended to be used by persons (including children) with restricted physical sensory or mental capabilities or with a lack of experience and/or knowledge, unless they are supervised by someone responsible for their safety or have received instructions from this person on how to use the device (e.g. from a doctor, trainer, etc.).
- Children must be supervised at all times to ensure that they do not play with the equipment.
- An additional consent is provided by the user when the Medical Disclaimer is acknowledged by pressing the button at the beginning of the training session in Power Training or Heart Rate Training Mode.

CAUTION:

The calculated FTP values are intended as a guide for users aged between 20 and 60. In order to receive precise values for younger and older users, please carry out the FTP (power) test.

HEART RATE TRAINING

FOLLOW THE STEP BY STEP DIRECTIONS CAREFULLY AS PROMPTED ON THE DISPLAY TO START A TRAINING SESSION.

The heart rate training mode has 4 screens that display different information during training. Toggle between the screens by pressing the arrow buttons.

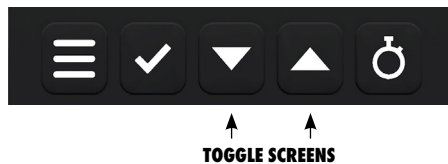

SCREEN 1

RPM Current cadence	LEVEL Resistance (0-100)
BPM Heart Rate	ZONE Current zone. Position in current zone.
LAP Distance /Time	LAST LAP Distance /Time

SCREEN 2

WATT Current Power Output	KCAL Calories Burned
MILES/KM Distancet	MPH/KMH Speed
WATT/KG Power/Weight Ratio	WATT/HR Power/Heart Rate Ratio

The Lap and Last Laps are displayed after at least one lap has been started and will automatically disappear 5 seconds after the lap has been stopped and will repeat once another lap has been started.

HEART RATE TRAINING

SCREEN 3

WATT AVG WATT MAX	BPM AVG BPM MAX
FTP %	MHR %
RPM AVG RPM MAX Cadence	MPH/KMH AVG MPH / KMH MAX Speed
WATT/KG AVG WATT/KG MAX Power	WATT/HR AVG WATT/HR MAX Power/HeartRate Average
LEVEL AVG/MAX Average/Max Level	TSS/ IF Training Stress Score / Intensity Factor

SCREEN 4

RED/ZONE 5 Time and % spent in zone	DISTANCE/KCAL Distance travelled in zone
YELLOW/ZONE 4 Time and % spent in zone	DISTANCE/KCAL Distance travelled in zone
GREEN/ZONE 3 Time and % spent in zone	DISTANCE/KCAL Distance travelled in zone
BLUE/ZONE 2 Time and % spent in zone	DISTANCE/KCAL Distance travelled in zone
WHITE/ZONE 1 Time and % spent in zone	DISTANCE/KCAL Distance travelled in zone

During the work out, the training zone you are currently training in is highlighted.

The actual time and percentage of the time spent in a zone during your training are displayed along with the traveled distance and burnt calories.

FTP RAMP TEST

The FTP (power) test makes it possible to determine a user's individual FTP value in an evaluation test, or to monitor the fitness progress.

The test is designed as a so-called "ramp test". As soon as the test is started, a target value of 75 watts (+/- 15W) is specified. The user taking the test is now requested to maintain a constant and comfortable cadence of between 70 and 90 RPM throughout the entire test and to turn the resistance dial to set the resistance so that the target value is achieved.

The target value must be reached within a window of max +/- 15 W deviation, otherwise the display changes to red. If the target value is met, the background changes to green. The target value increases every 4 minutes by 25 watts and the test can be ended at any time. After the first target value is reached after 4 minutes (75 watts for 4 minutes), the result is shown after ending the test. If it is interrupted beforehand, the test fails.

If you are notified that you have been outside the target range for longer than 24 seconds within a 4 minute ramp then a FTP value will be calculated but we would suggest you repeat the test for a more accurate result.

Please note that only fully completed ramps (4 minutes) are taken into consideration for the test results.

CAUTION

- The integrated FTP (power) test in the form of a 4 minute "ramp test" represents a subjective test, which the user can end at any point.
- The FTP (power) test should only be carried out under the supervision of a qualified and experienced trainer or instructor.
- It is recommended to constantly monitor the heart rate during the test, in order to control the physical exertion caused by the output power. Over-exertion must under no circumstances take place.
- Please also take note of the Medical Disclaimer.

Your current cadence. RPM	Your current resistance LEVEL
Your current power output WATT	Target Power Output TARGET
Time until next ramp is reached RAMP TIME	Current Ramp Number RAMP

FTP 5 MINUTE TEST

The 5 minute Functional Threshold Power test determines your FTP value and gives a personal value for setting intensity making your workouts more effective and allowing you to monitor your fitness progress.

The test is carried out by riding at a maximum sustainable effort of resistance for the full 5 minutes and by staying within the target cadence range of 80 - 100 RPM. The computer will light Green if you are pedaling within the cadence range and Red if you are pedaling too slow or too fast. If necessary during the test you may adjust the resistance during the test to achieve your maximum power output within the cadence range of 80 - 100 RPMs. Staying within the cadence range as much as possible will provide a more accurate test result.

Before you start the test, be sure you have completed a full warm up.

A 60 second countdown will commence the start of the test.

Begin pedaling and adjust the resistance and maintain the correct cadence.

Once you have finished the test, perform a proper COOL DOWN.

Note your FTP value for future use with Coach By Color Power Training and monitoring your fitness progress.

CAUTION

- The integrated FTP (power) test in the form of a 5 minute test represents a subjective test, which the user can end at any point.
- The FTP (power) test should only be carried out under the supervision of a qualified and experienced trainer or instructor.
- It is recommended to constantly monitor the heart rate during the test, in order to control the physical exertion caused by the output power. Over-exertion must under no circumstances take place.
- Please also take note of the Medical Disclaimer.

Your current cadence. RPM	Your current resistance LEVEL
Your current power output WATT	Avg. Power Output WATT AVG

FTP 20 MINUTE TEST

The 20 minute Functional Threshold Power test determines your FTP value and gives a personal value for setting intensity making your workouts more effective and allowing you to monitor your fitness progress.

The test is carried out by riding at a maximum sustainable effort of resistance for the full 20 minutes and by staying within the target cadence range of 70 - 100 RPM. The computer will light Green if you are pedaling within the cadence range and Red if you are pedaling too slow or too fast. If necessary during the test you may adjust the resistance during the test to achieve your maximum power output within the cadence range of 70 - 100 RPMs. Staying within the cadence range as much as possible will provide a more accurate test result.

Before you start the test, be sure you have completed a full warm up.
A 60 second countdown will commence the start of the test.
Begin pedaling and adjust the resistance and maintain the correct cadence.
Once you have finished the test, perform a proper COOL DOWN.

Note your FTP value for future use with Coach By Color Power Training and monitoring your fitness progress.

CAUTION

- The integrated FTP (power) test in the form of a 20 minute test represents a subjective test, which the user can end at any point.
- The FTP (power) test should only be carried out under the supervision of a qualified and experienced trainer or instructor.
- It is recommended to constantly monitor the heart rate during the test, in order to control the physical exertion caused by the output power. Over-exertion must under no circumstances take place.
- Please also take note of the Medical Disclaimer.

Your current cadence. RPM	Your current resistance LEVEL
Your current power output WATT	Avg. Power Output WATT AVG

DIRECT FTP ENTRY

The Direct FTP Entry mode must be enabled in the settings/system menu. If activated, you can enter your FTP value directly before starting a Power Training or Coach By Color® training.

RPM Current cadence	LEVEL Resistance (0-100)
WATT Current power output	ZONE Current zone.
LAP Distance /Time	LAST LAP Distance /Time

The Lap and Last Laps are displayed after at least one lap has been started and will automatically disappear 5 seconds after the lap has been stopped and will be displayed again once another lap has been started.

SETTINGS

To access the computer settings, a special key combination must be pushed which prevents unauthorized access of the settings menu.

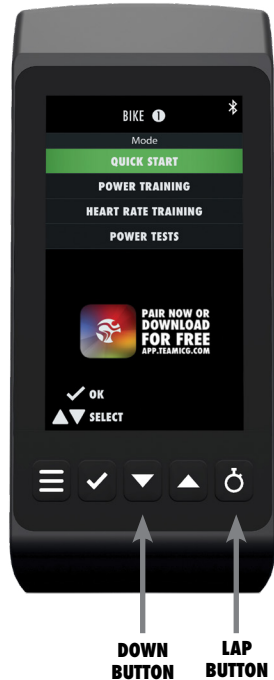

TO OPEN THE SETTINGS MENU:

1. Be sure you are in the mode selection screen (Start up screen)
2. Press the down button and the lap button at the same time for a minimum of 3 seconds.

Use the arrow keys within the menu navigation to navigate up or down as well as the confirm key to enter/confirm the relevant selection.

QUICK SETUP

When selected, the general settings can be entered in sequence as if bike is being setup for the first time. See Setup page 6.

SYSTEM

The following settings can be made in the system menu.

BIKE ID

The identification number is required for use with ICG Connect and App pairing.

APP ADVERT

When ON, a QR code with a download link will be displayed on the screen during startup.

LANGUAGE

Select

WEIGHT UNIT

Kg / Lbs

DISTANCE UNIT

KM / Mi

BRIGHTNESS

Adjusts the brightness of the screen.

PAUSE TIME

Length of pause during training can be adjusted in increments of 1 min.

DIRECT FTP ENTRY

Enables training option.

CONNECT

Your preferred connectivity settings can be turned off or on. See page 12 for functionality of each setting.

ANT+ SENSORS

BLUETOOTH SENSORS

ICG CONNECT

WIFI

COACH BY COLOR

COLOR MODE

Set the on screen Coach by Color setting.

FRONT LED

Turn the forward facing LED on or off.

KEY FUNCTIONS

The key functions within the various modes are as follows:

SETTINGS MODE		
Down arrow	Press	Scroll down / reduce value
Down arrow	Press and hold	Reduce the value incrementally
Up arrow	Press	Scroll up / increase value
Up arrow	Press and hold	Increase the value incrementally
Menu	Press	No function / exit menu, back
Confirm	Press	Confirm entry
Confirm and Lap	Press simultaneously for 3 seconds	none
USER MODE		
Down arrow	Press	Scroll down / reduce value
Down arrow	Press and hold	Reduce the value incrementally
Up arrow	Press	Scroll up / increase value
Up arrow	Press and hold	Increase the value incrementally
Menu	Press	Exit
Confirm	Press	Confirm entry
Confirm and Lap	Press simultaneously for 3 seconds	Open settings menu
TRAINING MODE		
Down arrow	Press	Switch to previous screen
Down arrow	Press and hold	No function
Up arrow	Press	Switch to next screen
Up arrow	Press and hold	No function
Menu	Press	Open user menu
Confirm	Press	Start pause mode
Confirm and Lap	Press simultaneously for 3 seconds	None

MAXIMUM DISPLAY RANGES

TRAINING VALUES		
DISPLAY VALUE	VALUE RANGE	UNITS
Distance	999.9	km or miles
Speed	99.9	km/h or MPH
Workout duration Duration in workout zones	99:59:59	hh:mm:ss
FTP %	unlimited	%
HR %	unlimited	%
HR BPM	30 – 250	BPM
LEVEL	0 – 100	%
RPM (1)	30 – 230	RPM
WATT (2)	0 – 2500	Watt
Calorie consumption	0 – 9999	kcal (displayed as CAL)
USER SETTINGS		
DISPLAY VALUE	VALUE RANGE	UNITS
Age	14 – 99	Years
Weight	34 – 150 or 75 - 331	kg or lbs (pounds)
HR max (4)	30 – 250	BPM
FTP Index (3)	0 – 2500	Watts

MAXIMUM DISPLAY RANGES

ABOUT (1):

From a cadence of 150 RPM, the value begins to flash. This is intended to indicate that you are exceeding the exercise range for which the bike was designed. From a cadence of 230, the RPM display is deactivated.

PLEASE NOTE:

If the bike is used at cadences of > 180 RPM for extended periods of time, all warranty claims are void.

ABOUT (2):

The power is only displayed from a rotational speed of 40 RPM, as only the power displayed here (wattage) is in the ensured tolerance range of $\pm 5\%$.

ABOUT (3):

Value can only be adjusted in the power and heart rate training modes

ABOUT (4):

Value can only be adjusted in the power and heart rate training modes and if "CONNECT HR SENSOR" is selected with "YES" in the menu.

PLEASE NOTE:

If the maximum value has been reached, the respective value is reset to "0".

EU- DECLARATION OF CONFORMITY

The electronic components satisfy the EMV Directive 2014/53/EU, EMV Directive 99/519/EC, and DIN EN 60335-1:2012/A14:2019 for electrical safety.

The Declaration of Conformity can be viewed at www.indoorcycling.com



FCC COMPLIANCE

This device complies with part 15 of the FCC rules. Operation is subject to the following two conditions: (1) This device may not cause harmful interference, and (2) this device must accept any interference received, including interference that may cause undesired operation. Note: This equipment has been tested and found to comply with the limits for a Class B digital device, pursuant to part 15 of the FCC Rules. These limits are designed to provide reasonable protection against harmful interference in a residential installation. This equipment generates, uses, and can radiate radio frequency energy and, if not installed and used in accordance with the instructions, may cause harmful interference to radio communications. However, there is no guarantee that interference will not occur in a particular installation. If this equipment does cause harmful interference to radio or television reception, which can be determined by turning the equipment off and on, the user is encouraged to try to correct the interference by one or more of the following measures: • Reorient or relocate the receiving antenna. • Increase the separation between the equipment and receiver. • Connect the equipment to an outlet on a circuit different from that to which the receiver is connected. • Consult the dealer or an experienced radio/TV technician for help. Important: Changes or modifications to this product not authorized by Indoor Cycling Group could void the electromagnetic compatibility (EMC) and wireless compliance and negate your authority to operate the product. This product has demonstrated EMC compliance under conditions that included the use of compliant peripheral devices and shielded cables between system components. It is important that you use compliant peripheral devices and shielded cables between system components to reduce the possibility of causing interference to radios, televisions, and other electronic devices.

Canadian regulatory statement This device complies with Industry Canada licence-exempt RSS standard(s). Operation is subject to the following two conditions: (1) this device may not cause interference, and (2) this device must accept any interference, including interference that may cause undesired operation of the device.

Le présent appareil est conforme aux CNR d'Industrie Canada applicables aux appareils radio exempts de licence. L'exploitation est autorisée aux deux conditions suivantes : (1) l'appareil ne doit pas produire de brouillage, et (2) l'utilisateur de l'appareil doit accepter tout brouillage radioélectrique subi, même si le brouillage est susceptible d'en compromettre le fonctionnement.

DISPOSAL ELECTRIC WASTE

EUROPEAN UNION ONLY

This symbol indicates that the product it is referring to may not be disposed of along with normal household waste. If you wish to dispose of this device, do not throw it away along with normal waste! There is a separate collection system for products of this description.



This symbol is only valid in the European Union.

OTHER COUNTRIES OUTSIDE OF THE EUROPEAN UNION

If you would like to dispose of this product, please adhere to the relevant state laws and other regulations in your country concerning the treatment of electronic devices.

BUSINESS CUSTOMERS

If you would like to dispose of this product, please get in touch with our service.

SOFTWARE LICENCE NOTICE

Certain ICG products (including but not limited to MyRide V3, MyRidePlus, MyRide VX, ICG Connect, Wattrate® TFT Computer etc.) contain open source software. For further details, please visit <https://support.teamicg.com> or contact support@indoorcycling.com

CAUTION.

READ ALL PRECAUTIONS AND INSTRUCTIONS IN THIS MANUAL BEFORE YOU BEGIN USING THIS EQUIPMENT. PLEASE KEEP THIS MANUAL FOR FUTURE REFERENCE. IMPROPER ASSEMBLY, SET UP, USE OR MAINTENANCE MAY VOID THE WARRANTY.



EMAIL: INFO@INDOORCYCLING.COM
WEBSITE: WWW.INDOORCYCLING.COM

© 2023 Cy-Tech GmbH

Manufactured by: Cy-Tech GmbH
Happurger Str. 86 90482 Nuremberg Germany