

**MANUFACTURED BY:**

Cy-Tech GmbH
Happurger Str. 86
90482 NUERNBERG | Germany
info@indoorcycling.com
www.indoorcycling.com
Phone: +49(0)911 / 54 44 50

IC4

MODEL NO:IC-IC4B1-01**CAUTION!**

READ ALL PRECAUTIONS AND INSTRUCTIONS IN THIS MANUAL BEFORE YOU START USING THIS EQUIPMENT. PLEASE KEEP THIS MANUAL FOR FUTURE REFERENCE. IMPROPER ASSEMBLY, USE OR MAINTENANCE CAN VOID THE WARRANTY TERMS.

ADDITIONAL LANGUAGES AVAILABLE FOR DOWNLOAD AT WWW.INDOORCYCLING.COM

Version 2.0 2021 IC-IC4B1-01 Copyright by Cy-Tech GmbH 2023 | www.indoorcycling.com



ATTENTION

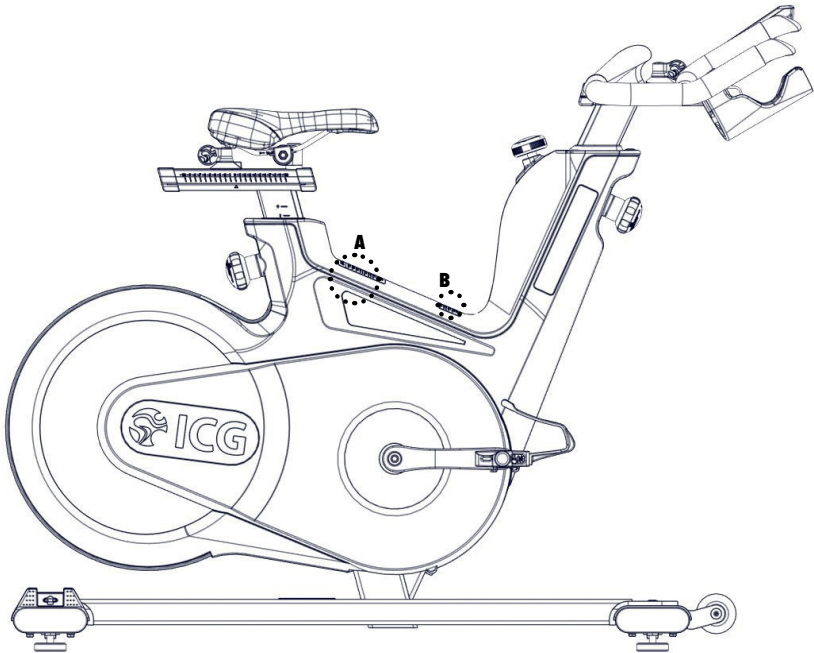

Warning labels on the bikes must be replaced by warning labels in your language during the assembly process.

A

⚠ WARNING

1. Misuse of this machine may result in serious injury.
2. Read user manual prior to use and follow all warnings and instructions.
3. Replace label if damaged, illegible or removed.
4. Keep children away.
5. Use only on a level surface.
6. Maximum user weight: 110kg (243lb).
7. Spinning pedals can cause injury.
8. This bike does not have wheels.
9. Pedal speed should be reduced in controlled sessions.

WARNING: ...
Use this indoor training equipment in a supervised environment.

B

⚠ WARNING

After deploying the E-Drive:

1. Ensure flywheel is at a full stop.
2. Release brake pressure.
3. Release pressure on the pedals.
4. Begin pedaling. Don't pedal backwards. Limited E-Drive functionality while pedaling backwards.

ATTENTION



EN

To download the owners manual in your language, visit the IC4 support section at: www.teamicg.com



DE

Um das Handbuch in Ihrer Sprache herunterzuladen, besuchen Sie bitte den IC4 Support Bereich auf unserer Webseite unter www.teamicg.com



FR

Pour télécharger le manuel d'utilisation dans votre langue, consultez la section Assistance IC4 sur: www.teamicg.com



IT

Per scaricare il manuale nella vostra lingua, visitate la sezione del supporto per IC4 su: www.teamicg.com



NL

Ga om de gebruiksaanwijzing in uw taal te downloaden naar het IC4 supportgedeelte onder: www.teamicg.com



ES

Para descargarse el manual de usuario en su idioma, por favor acceda a la sección de soporte técnico de la bici IC4 en: www.teamicg.com



PT

Para transferir o manual de utilizador no seu idioma, visite a secção „Suporte“ da IC4 em: www.teamicg.com



DK

Besøg IC4 supportafsnittet www.teamicg.com for at downloade brugermanualen på dit sprog



FI

Lataa omistajan käsikirja omalla kielelläsi IC4-ohjeosiosta sivustolta: www.teamicg.com



NO

Du kan laste ned bruksanvisningen på ditt eget språk ved å gå til IC4 støttesiden på: www.teamicg.com



SE

Du kan hämta bruksanvisningen på ditt språk under IC4-support på www.teamicg.com



PL

Aby pobrać podręcznik użytkownika w swoim języku, należy wejść na zakładkę IC4 support na stronie: www.teamicg.com



TR

Kullanıcı kılavuzunu kendi dilinizde indirmek için www.teamicg.com sayfasının IC4 deste bölümünü ziyaret edebilirsiniz



CN

在IC4的客户服务网站，您可以下载各种语言的用戶手册 www.teamicg.com



JP

オーナーズマニュアルの各言語版は、以下サイトの IC4 サポートページからダウンロードいただけます。 www.teamicg.com



KR

IC4 지원 센터(www.teamicg.com)에서 해당 언어 버전의 사용설명서를 다운로드할 수 있습니다..

TABLE OF CONTENTS

IMPORTANT PRECAUTIONS P.5
GETTING STARTED P.6
HOW TO ASSEMBLE THE INDOOR CYCLE P.7-11
INSTALLATION AND SETUP P.12
HOW TO ADJUST THE INDOOR CYCLE P.13-15
HOW TO OPERATE THE INDOOR CYCLE P.16-18
PREVENTIVE MAINTENANCE P.19-22
MAINTENANCE ACTIVITY AND REQUIRED SCHEDULE P.23-24
SPARE PARTS P.25
WARRANTY P.26

TECHNICAL SPECIFICATIONS:

The IC4 Bike is, according to EN ISO 20957-1 and EN ISO 20957-10 , a Class S product for use in a controlled environment such as sports or fitness facilities under the supervision of a trainer.

WEIGHT OF BIKE:	50 KG
MAX USER WEIGHT:	150 KG
USER HEIGHT:	SUITABLE FOR USERS BETWEEN APPROX. 155 AND 215 CM
REQUIRED FOOT PRINT:	APPROX. 132 X 52 CM
MAX SADDLE & HANDLEBAR HEIGHT:	APPROX. 120 CM

IMPORTANT PRECAUTIONS

WARNING!

To reduce the risk of serious injury due to improper use of the equipment, carefully read and adhere to the following important precautions and information before operating the indoor cycle!

1. It is the responsibility of the owner to ensure that all users are informed of all warnings and precautions for proper use, and are only authorized to use the bike independently after being successfully briefed by a qualified trainer or instructor.
2. Do not operate the bike until it has been properly assembled and inspected as described in this manual.
3. Keep the indoor cycle indoors, away from moisture and dust. Do not place the indoor cycle outdoors in a garage or covered patio or near water or pools. Operating temperature of the Indoor Cycle has to be between 15°C~ 40°C Celsius (59°~104°F) at max. humidity of 65%.
4. Always place the bike on a stable, level surface. If the bike is to be placed on a hardwood floor or carpet, it is recommended to place a floor mat beneath the bike, to protect the floor from becoming damaged.
5. The level of safety of the Indoor Bike can only be guaranteed if it is regularly checked for possible damage as well as wear and tear (e.g. fixing points, E-Brake, Pedals, toe straps, etc.). Consult an authorized service provider or the manufacturer direct to ensure the regular inspections are properly carried out.
6. Carry out all maintenance, care and service procedures as described in this manual on a regular basis. Defective parts must be replaced immediately, and the device must not be used until the repairs have been carried out.
Only use original parts from the manufacturer. Repairs must only be carried out by manufacturer authorized service technicians.
7. Unsupervised children should be kept away from the training device at all times.
8. **WARNING:** The training equipment can be used by children aged from 14 years and above and persons with lack of experience and knowledge if they have been given supervision or instruction concerning use of the appliance in a safe way and understand the hazards involved. Children under 14 years of age and Persons with reduced physical, sensory or mental capabilities are prohibited from using the training equipment. Cleaning and user maintenance shall not be carried out by children without supervision. Children shall not play with the appliance.
9. The indoor cycle must not be used by persons exceeding weight of 330 lbs/150 kg.
10. Always wear appropriate tight-fitting cycling or athletic attire and sturdy shoes, preferably cycling shoes, while operating the bike. Unfastened shoelaces may become caught in the drive system and lead to injury.
11. The bike does not have an independently-moving flywheel. The pedals will continue to move with the flywheel until the flywheel stops. The movement can only be stopped by using the emergency brake or by reducing the pedaling frequency in a controlled manner. Always ride with resistance load to ensure that your pedaling motion is controlled. Do not adjust handlebar or saddle during workout. Do not pedal backwards.
12. If you feel physical discomfort or dizziness, stop training and consult a physician. If the user requires medication that has effect on their performance capabilities and/or cardiovascular system, it is imperative that they consult a doctor in order to adjust the personal entries accordingly.
13. Only exercise within your physical limitations.
14. This stationary training equipment is not suitable for high accuracy purposes.

WARNING!

If you have pre-existing health problems or a disability, it is recommended that you consult your physician, in order to find the training method which is best suited to you. Incorrect or extensive training can result in serious health injuries.

The manufacturer expressly assumes no responsibility for health risks, personal injury, property damage or consequential damages sustained by or through the use of this device, unless it is a case of consequential damage which can be traced back to faulty material and/or manufacturing, and which come under the responsibility of the manufacturer.

GETTING STARTED

DEAR CUSTOMER,

The ICG Indoor Cycle offers an impressive array of features to improve cardiovascular fitness, tone muscles and develop endurance.

This high level of reliability can however only be ensured with regular care and maintenance. Adhering to the maintenance procedures outlined in this manual will ensure a maximized stability and prolonged lifespan in return for minimal maintenance effort. This will guarantee long-standing, interruption-free operation.

WARNING!

- Do not exercise beyond your ability.
- If you feel physical discomfort or dizziness, stop training and consult a physician.
- If the user requires medication that has an effect on their performance capabilities and/or cardiovascular system, it is imperative that they consult a doctor in order to adjust the personal entries accordingly.

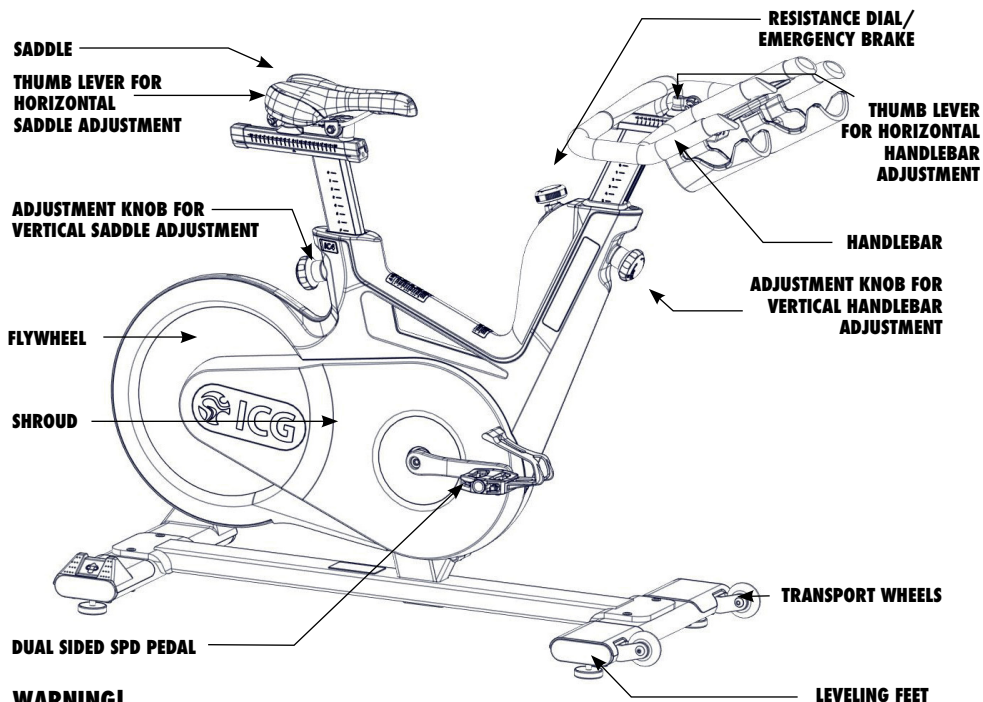

WARNING!

You will find the production code for the IC4 Bike on the tag plate which is located on top of the lateral frame tube of the Indoor Bike. Please enter this production code into care and maintenance lists. It is a strict requirement to provide the production code in all warranty claims.

HOW TO ASSEMBLE THE INDOOR CYCLE

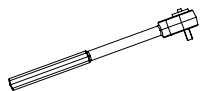

TORQUE WRENCH

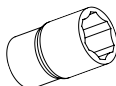

17MM



**2
PEOPLE**

WARNING!

Avoid high fluctuations in temperature whilst transporting the bike from the store to the installation site. If there are nevertheless large fluctuations in temperature, please allow the bike to acclimatize to the surrounding temperature before proceeding with assembly.

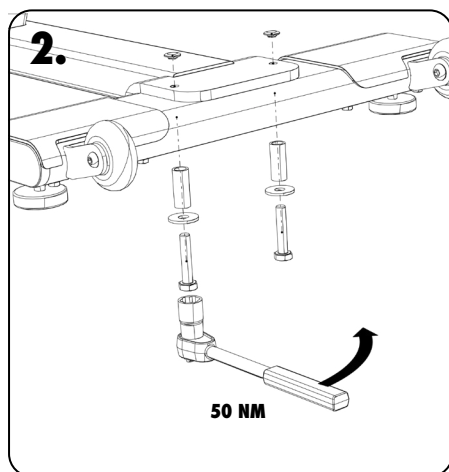
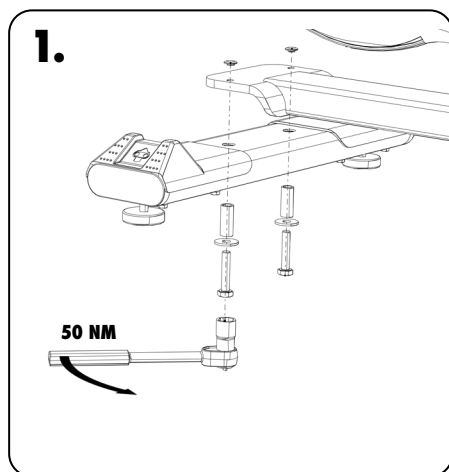

WARNING!

Please ensure that bolts are tightened with the specified force to minimize loosening during use. If bolts are loosened after initial assembly, we recommend using medium-strength LOCTITE® 243 when reassembling.

HOW TO ASSEMBLE THE INDOOR CYCLE

DANGER OF INJURY!

DO NOT REMOVE THE SAFETY PIN BEFORE THE HANDLEBAR HAS BEEN MOUNTED ON THE UPPER HORIZONTAL HANDLE BAR SLIDER!

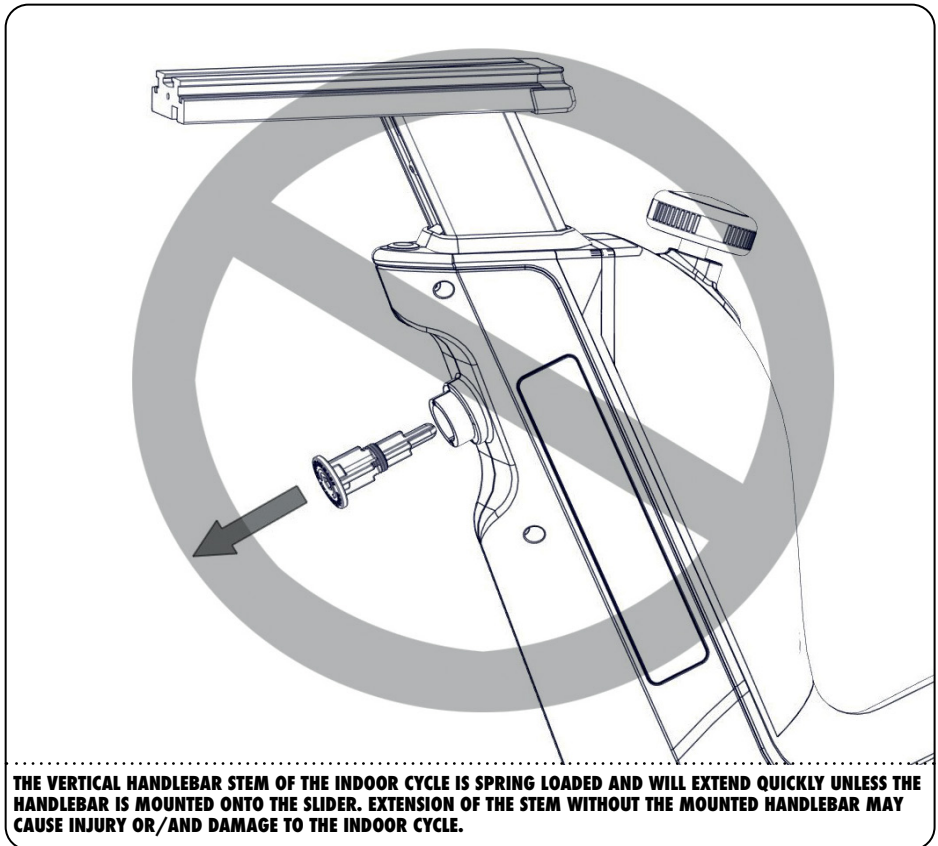

HOW TO ASSEMBLE THE INDOOR CYCLE

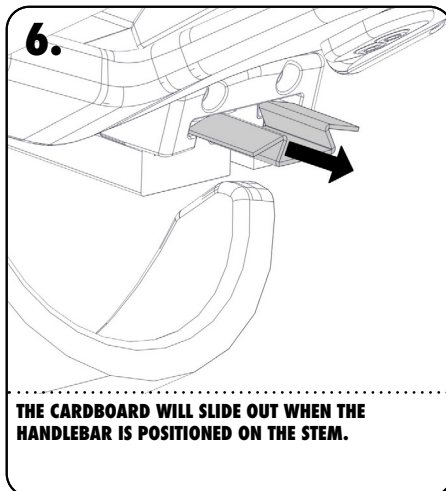
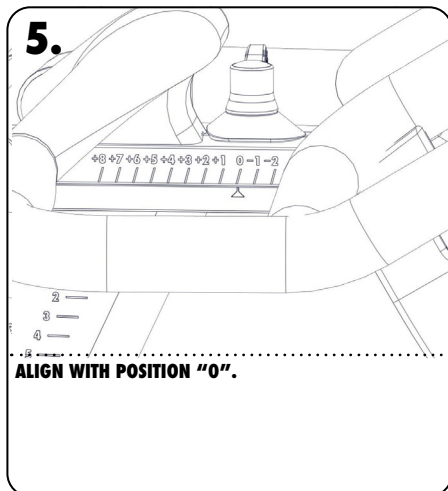
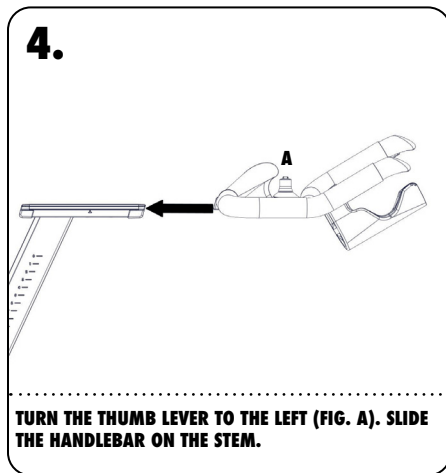
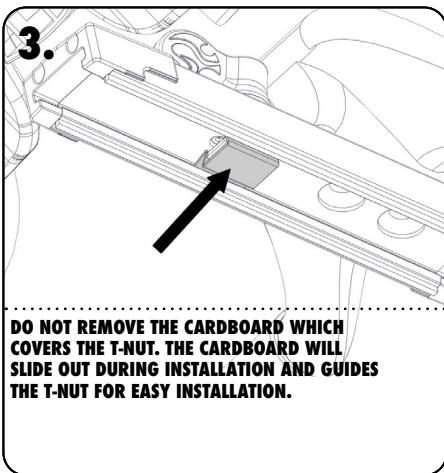

HOW TO ASSEMBLE THE INDOOR CYCLE



3 & 6MM

7.

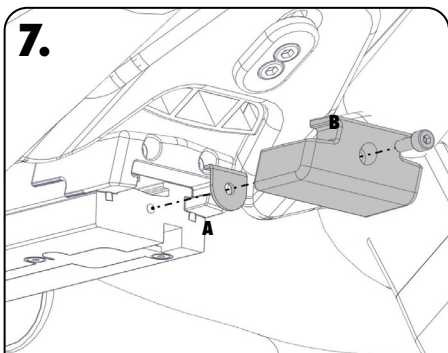

MOUNT THE METAL LIMIT STOP (FIG. A) AND THE PLASTIC CAP (FIG. B) WITH A 3 MM HEX KEY.

8.

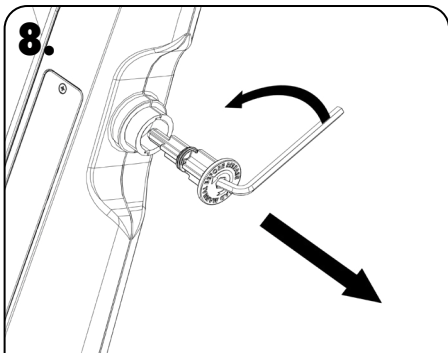

LOOSEN THE SAFETY PIN AND REMOVE IT USING A 6 MM HEX KEY.

9.

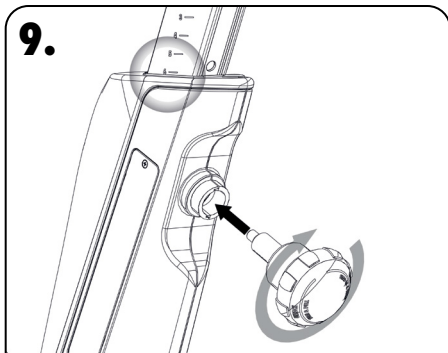

LIFT THE HANDLEBAR TO POSITION 6 AND SCREW THE POP PIN KNOB COMPLETELY INTO THE FRAME TO LOCK THE HANDLEBAR STEM.

HOW TO ASSEMBLE THE INDOOR CYCLE



15 MM PEDAL WRENCH



HAND TIGHT



2 PEOPLE



PHILLIPS SCREWDRIVER

11.

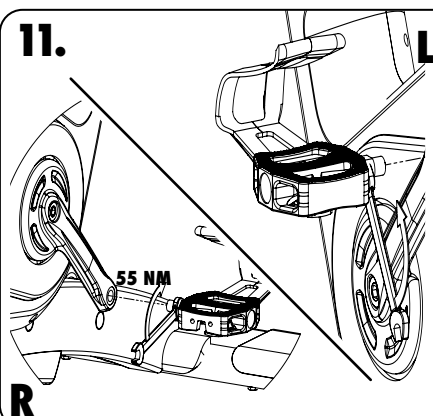

WARNING!

Attach the pedal marked R on the right crank and tighten by turning clockwise (standard right-hand thread). Attach the pedal marked L on the left crank and tighten by turning counter-clockwise (left-hand thread). Please make sure that both pedals are fastened with sufficient force (55 NM), to ensure that the bolt does not become loose during use.

The threads are provided with TufLok® at the factory to prevent them from becoming loose during use. If bolts are loosened after initial assembly, we recommend using medium-strength LOCTITE® 243 when reassembling.

12.

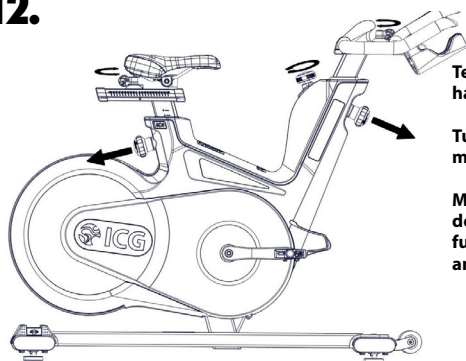

Test the function of the adjustable handlebar and seat.

Turn the resistance dial left and right multiple times

Move the handlebars and seat up and down and the back and forth. Test the function of the thumb levers on the sliders and the function of the pop pin knobs.

TEST FUNCTION OF HANDLEBAR AND SEAT HEIGHT ADJUSTMENT, HORIZONTAL SLIDERS AND EMERGENCY BRAKE.

INSTALLATION AND SETUP

Instructions stated in this manual must be performed during initial installation of the Indoor Cycle in order to ensure optimal performance and a long lifespan. Please read and follow the following instructions carefully. If the Indoor Cycles are not installed and configured as described, the components may be subjected to excessive wear and tear and the bike may become damaged. If you have any questions regarding installation, please contact service@indoorcycling.com.

Please note: Lubricants are required for some maintenance procedures. Please only use an **acid- and solvent-free spray lubricant** and white lithium grease.

- 1.** Make sure the bike is level. If bike rocks on the floor, turn the levelling feet underneath the front and/or rear stabilizer until the rocking motion is eliminated. Make sure that the levelling feet are not screwed out further than 10 mm
- 2.** Verify emergency brake function to make sure that it is working properly.
- 3.** Check that both crank arm Allen bolts, with which the cranks (on the right and left side of the bottom bracket) are fastened, are secure (tightening torque 60 NM). These bolts are provided with TufLok® at the factory to prevent them from becoming loose during use.

If the bolts become lose, we recommend applying medium-strength LOCTITE® 243 and then reattaching the crank fixing bolts with a tightening torque of 60 NM.

- 4.** Wipe down bike frame with a rag moistened with acid- and solvent-free spray lubricant.
- 5.** Some parts of the bike may become loose during shipment. Check crank arms and all exposed screws, bolts and nuts, and make sure that they are all secure and properly tightened.

CUSTOMER SERVICE

- 1.** Provide the customer with basic maintenance instructions, and direct them to detailed maintenance instructions.
- 2.** Have the sign-off sheet for the manual, explanation of maintenance procedures and verification of impeccable condition of the bikes confirmed by the customer when handing over the goods. A copy of this confirmation counter-signed by yourself is withheld by the customer.
- 3.** Repairs must only be carried out by manufacturer authorised service technicians.

HOW TO ADJUST THE INDOOR CYCLE

The Indoor Cycle can be very easily adjusted, depending on the requirements of various user groups. This enables maximum riding comfort to be ensured whilst achieving optimal training results. The configurations described in the following paragraphs demonstrate just a few of the most often used adjustment variations of which the Indoor Cycle is capable. It is up to the user to adjust the Indoor Cycle to a riding position best suited to their requirements.

ADJUSTING THE SEAT HEIGHT:

Sit on the saddle and ensure that your hip is not tilted to one side when the pedal has assumed the position as shown in the picture. Place your shoes in the toe clips (cages) on the pedals, or in the SPD cleats if you are using cycling shoes.

VERTICAL SADDLE ADJUSTMENT

1. LOOSEN

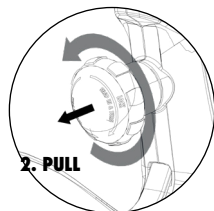

VERTICAL HANDLEBAR ADJUSTMENT

1. LOOSEN

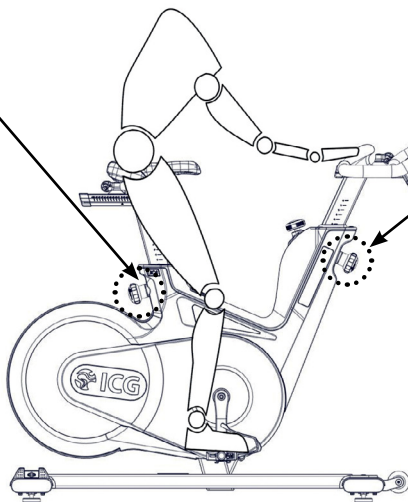
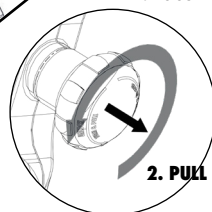

WARNING!

Do not adjust seat and handlebar during exercise. Ensure that the pop-pin-knobs used for the height adjustment of the handlebar and seat are properly tightened and the thumb levers for horizontal adjustment are closed, before you sit on the bike. Always step off the bike when making adjustments to the handlebars and/or saddle.

Start pedaling slowly, until the pedal has reached the position as shown in the picture. The saddle height should be adjusted so that your knees are always slightly bent when the pedal is at its lowest position without dropping your hip to one side. Rule of thumb: When standing next to the bike, the upper edge of the saddle should be a hand's width/four fingers below your iliac crest. Please avoid cycling with your knees fully extended or your hip tilted to one side.

HOW TO ADJUST THE INDOOR CYCLE

ADJUSTING THE SADDLE HORIZONTALLY:

Properly positioning the saddle horizontally is very important in order to avoid injury to the knees. Sit on the saddle and move the pedals until the crank arms are in the horizontal position.

The knee of your forward-facing leg should be positioned directly above the center of the pedal. If this does not correspond to your bike's setting, please align the horizontal saddle adjustment to the front or rear in order to attain this seat position.

HORIZONTAL SADDLE ADJUSTMENT

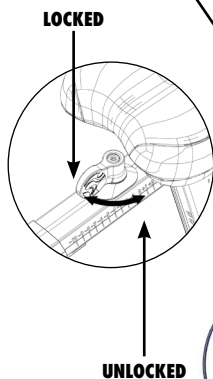

HORIZONTAL HANDLEBAR ADJUSTMENT

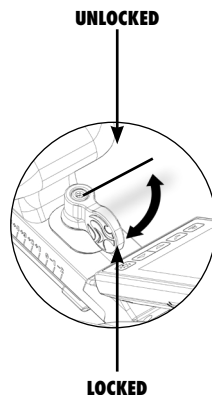

WARNING!

Ensure that the pop-pin-knobs used for the height adjustment of the handlebar and seat are properly tightened and the thumb levers for horizontal adjustment are closed, before you sit on the bike. Always step off the bike when making adjustments to the handlebars and/or saddle.

HOW TO ADJUST THE INDOOR CYCLE

HANDLEBAR POSITIONING:

Begin with the top of the handlebars at approximately the same height as the saddle (**dotted horizontal line A in the drawing below**) for inexperienced users set to the "0" marking (**see dotted vertical line B in the drawing below**). If your knees touch the handlebars or if you experience back discomfort when pedalling in the standing riding position for extended periods, the handlebars should first be adjusted slightly higher.

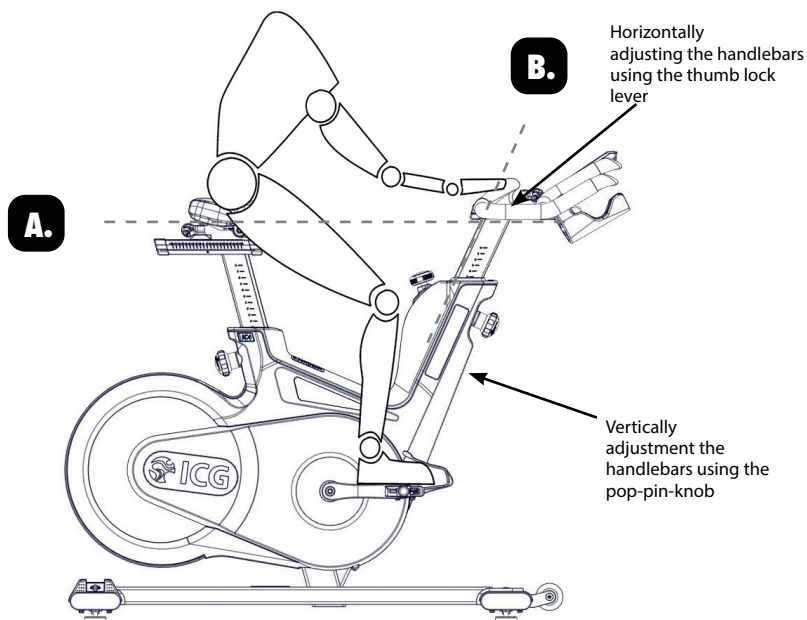

The next step is to adjust the horizontal position of the handlebars as precisely as possible to your height. An ideal and comfortable seating position for inexperienced riders is achieved if your back assumes an inclination angle of 45° in reference to the horizontal line (A).

The handlebars offer a wide variety of hand positions and adjustment possibilities, which provide the experienced rider with every possibility to find his/her ideal seating and hand positioning.

It is recommended to change hand positions frequently during extended workouts in order to minimise one-sided and monotonous exertions on your muscles, ligaments and joints.

HOW TO OPERATE THE INDOOR CYCLE

RESISTANCE ADJUSTMENT:

The resistance adjustment can be set precisely and regulated in fine increments according to the requirements of the cyclist using the resistance adjustment knob with a range of motion of 300°. The resistance in % (where 0% is no resistance and 100% is maximum resistance) is also displayed on the Indoor Cycle computer display.

To increase the resistance, turn the resistance adjustment knob clockwise. To decrease the resistance, turn it counter-clockwise. For a magnetic brake system, like the one fitted to this Indoor Cycle, the magnetic resistive effect also increases with pedalling frequency.

Never pedal backwards under resistance, as this can loosen the screws between the pedals and the crank arm and the two may even become detached. To stop the flywheel during use, the resistance knob/emergency brake knob must be pressed down. During training, please make sure your shoes are placed in the toe clips (cages) provided or if you are using cycling shoes, that they are connected with the SPD cleats.

The Indoor Bike does not have a free-moving flywheel. The flywheel is firmly connected to the pedals and does not stop independently if the user stops pedalling. Please always check your movements and reduce speed in a controlled manner to stop or simply press the red resistance/emergency brake knob down to quickly slow down the movement and in so doing bring the flywheel to a stop and suspend the training session.

Emergency brake = press down red resistance/emergency knob.

If the emergency brake has been activated, it can only be disengaged again when the flywheel has come to a complete standstill and the pressure has been removed from the pedals.

WARNING!

The Indoor Cycle shall only be operated in forward pedaling motion. The emergency brake functionality is limited when pedaling backwards. Do not attempt to adjust seat and handlebar in vertical or horizontal position while riding or seated.

HOW TO OPERATE THE INDOOR CYCLE

RESISTANCE DIAL

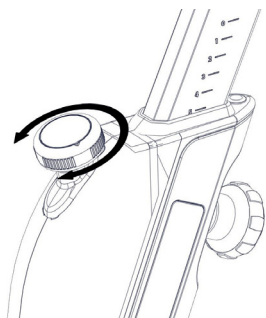

EMERGENCY BRAKE (PUSH ADJUSTMENT DIAL)

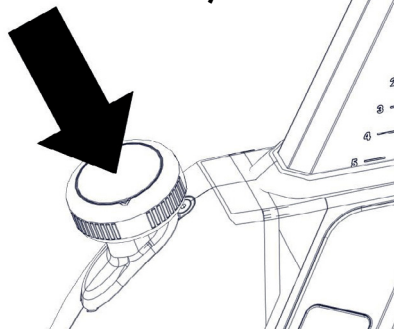

For safety reasons, please always make sure you pedal in a controlled manner and adjust your pedalling frequency to your own cycling capabilities.

MOVING THE INDOOR CYCLE:

It is recommended that two people move the Indoor Cycle. In order to prevent accidents and damage to the plug-in sockets of the handlebars it is necessary to firmly fix the vertical handlebar adjustment before the wheel is tilted. Please take extra care when moving the Indoor Cycle over uneven surfaces. A second person is advisable here, to prevent the cycle from tilting to one side. **Allow a minimum safety distance away from the nearest equipment, objects or walls as illustrated below.**

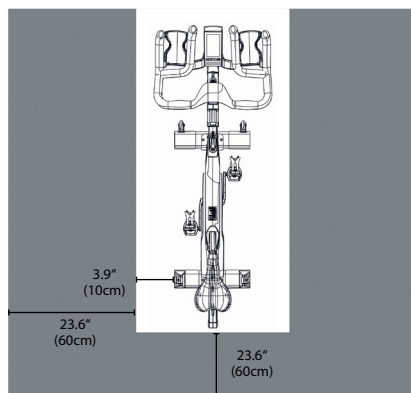
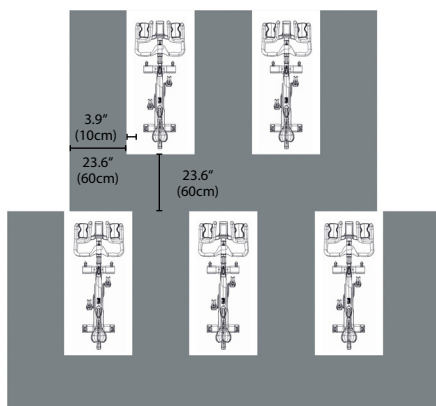

HOW TO OPERATE THE INDOOR CYCLE

Check the stability of the Indoor Cycle where it is to be operated and if necessary adjust the levelling feet underneath the front or rear stabilizers to ensure the desired stability.

IMPORTANT!

Please do not unscrew the levelling feet more than 10 mm! The free standing Indoor cycle shall only be installed and operated on a stable and leveled floor.

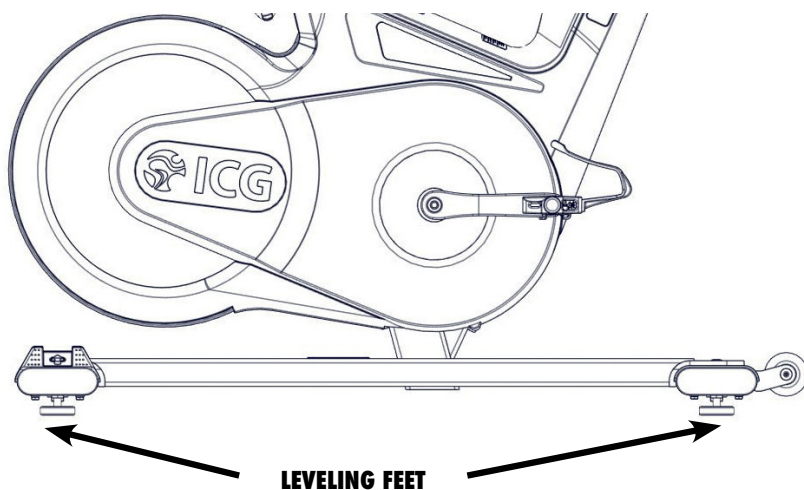

PREVENTIVE MAINTENANCE

WARNING!

Please carefully observe the following instructions. The maintenance and care procedures must be performed in the regularity set out, to ensure maximum operating safety and lifespan. Irregularly observed maintenance and care procedures will lead to increased wear to the product and will void the warranty. If you have any further questions on this topic, please contact our technical support.

Please only use the acid- and solvent-free maintenance and care agent (e.g. Brunox) recommended by us to prevent damage to components of the Indoor Cycle.

DAILY MAINTENANCE:

1. Make sure that the Indoor Cycle is leveled and does not rock (if necessary adjust as described on p. 18).

2. Cleaning: The Indoor Cycle must be regularly cleaned after each use for reasons of hygiene. Ensure that there are sufficient soft cloths or paper towels and maintenance and disinfection agent available. First disinfect the saddle and handlebars with a suitable agent and then wipe all bodily residues off the entire Indoor Cycle.

WEEKLY MAINTENANCE:

1. Cleaning: Depending on how often the Indoor Cycle is used, it must be extensively cleaned once a week. To do this, spray a maintenance spray onto a soft cloth and clean all plastic parts, the entire flywheel, exposed framework parts including stabilizers and the plastic casing.

Never spray maintenance spray or anything else directly onto the flywheel or pedal to ease cleaning, as this could cause the drive belt to slip during use, reduce braking performance or damage internal components.

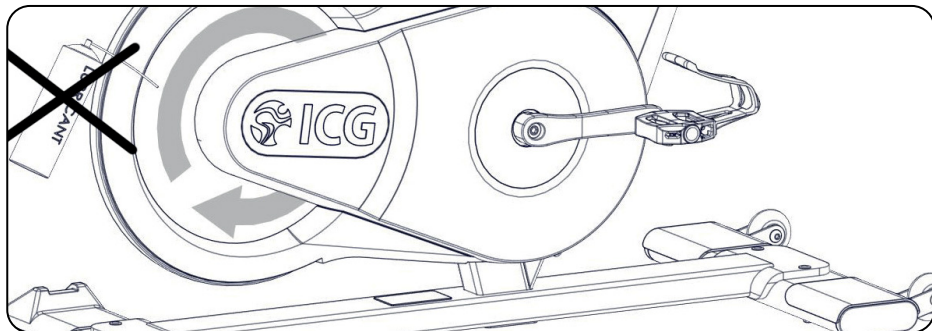

PREVENTIVE MAINTENANCE

BI-WEEKLY MAINTENANCE:

1. Emergency brake: To ensure operating safety, the emergency brake must be regularly checked to make sure it is functioning properly. To do this, completely press down the resistance/brake dial whilst pedalling. When functioning optimally, it should produce an immediate braking effect and bring the flywheel to a complete standstill.

The flywheel is only released again by the emergency braking function after coming to a complete standstill and when the pressure is removed from the pedals.

2. Saddle adjustments: To maintain the easy adjustment, the vertical and horizontal saddle posts must be regularly cleaned and lubricated. To do this, position the vertical saddle post **(A)** in the uppermost position, spray with maintenance spray and rub down the entire exterior surfaces including the horizontal post with a soft cloth.

Clean sweat residues off the contact surfaces **(B)** of the horizontal saddle post beforehand and if necessary apply a small amount of lithium/grease.

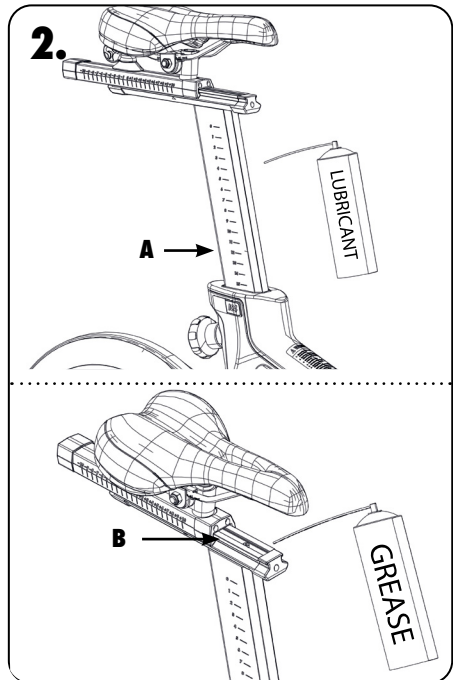
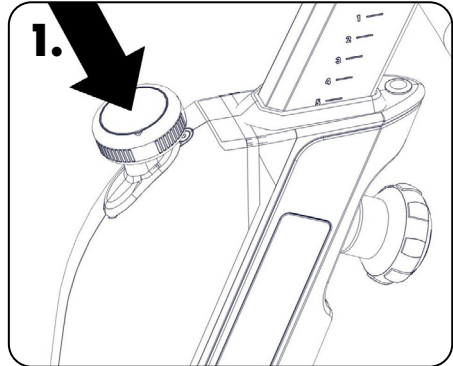

PREVENTIVE MAINTENANCE

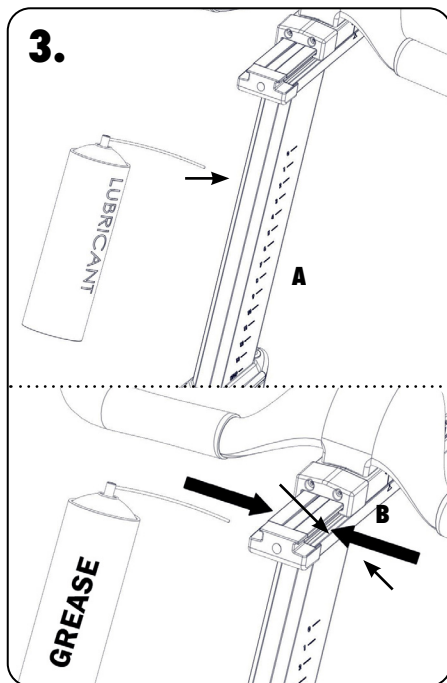

3. Handlebars: To maintain the easy adjustment of the handlebar posts, the vertical and horizontal handlebar posts must be regularly cleaned and lubricated. To do this, position the handlebars (A) in the uppermost position, spray the handlebar posts with maintenance spray and rub down the entire exterior surfaces including the horizontal post with a soft cloth. Clean sweat residues off the contact surfaces of the horizontal handlebar post (B) beforehand and if necessary apply a small amount of lithium grease.

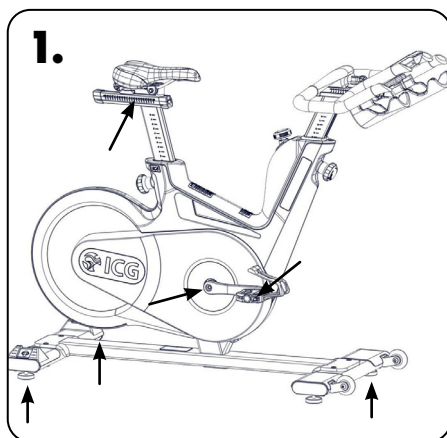

MONTHLY MAINTENANCE:

1. Connecting elements: During the course of regular maintenance and care procedures, all bolts, nuts etc. on the Indoor Cycle must be checked to ensure that they are properly tightened and function correctly. Parts showing wear or damage (saddle, pedal teeth, pedals, SPD system) must be replaced.

PREVENTIVE MAINTENANCE

2. Vertical adjusting of the handlebar and saddle:

To ensure the easy adjustment of the vertical handlebar and saddle posts, the thread on the pop-pin-knob must be lubricated. We recommend lithium grease.

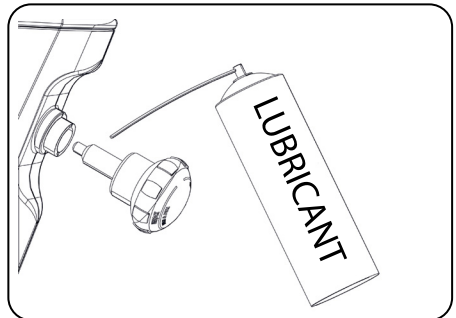
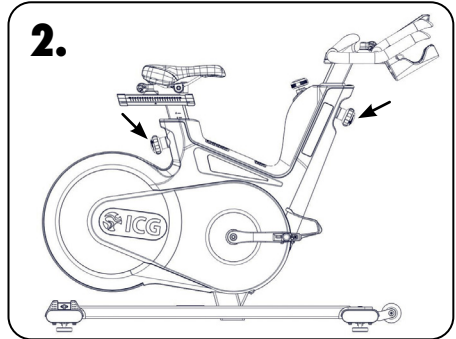

MAINTENANCE ACTIVITY AND SCHEDULE

BI-WEEKLY MAINTENANCE CHECKLIST					
BIKE NO.	PRODUCTION CODE	OBSERVATIONS	ACTION TAKEN	RESULT	NAME / DATE

MONTHLY MAINTENANCE CHECKLIST					
BIKE NO.	PRODUCTION CODE	OBSERVATIONS	ACTION TAKEN	RESULT	NAME / DATE

SPARE PARTS

Due to revisions, spare part order no. and specifications may be subject to change.
For further information please contact your local distributor or visit www.indoorcycling.com.

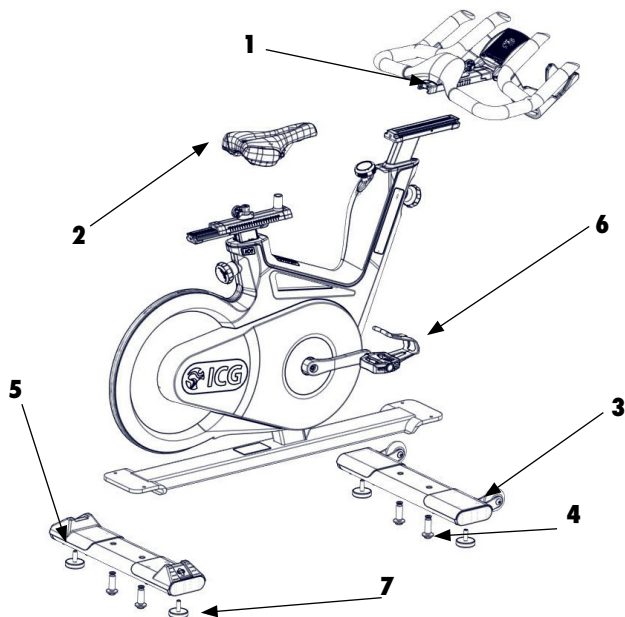

	DESCRIPTION	ITEM NUMBER
1	HANDLEBAR ASSEMBLY	110-01-00009-02
2	SADDLE	120-01-00076-01
3	1 PCS.FRONT STABILZER	140-02-00003-01
4	1 PCS. FRONT / REAR STABILZER MOUNTING HARDWARE	190-01-00004-01
5	REAR STABILZER	140-02-00002-01
6	PEDALS	150-01-00005-03
7	2 PCS LEVELLING FEET	190-01-00027-01

WARRANTY

ICG warrants that all new equipment will be free of manufacturing defects in workmanship and materials, effective on the date of original assembly at its production facility. Parts repaired or replaced under the terms of this warranty will be warranted for the remainder of the original warranty period only. ICG is obligated to uphold its manufacturer warranty obligation so long as the product is used in the closed environment it was designed for, Temperature range between 15°C~40°C Celsius (59°F~104°F) and max. 65% humidity (not near a swimming pool or outdoors). Defects caused by obvious deliberate mechanical impact, inappropriate use or undo handling of the product may cause the manufacturer's warranty to become void. In order for the manufacturer to uphold the warranty coverage, the customer (fitness facility) is obligated to maintain and service the product as per the manufacturer's specifications stated in the owner manual of each product.

5 YEARS WARRANTY:

FRAME CONSTRUCTION AND WELDING

3 YEARS WARRANTY:

POWDER COATING (PAINT CRACKS, CORROSION)

HANDLEBAR AND SEAT POST ASSEMBLY

(ALUMINUM PARTS AND PVC COATING)

BELT DRIVE SYSTEM

POWER SENSOR

BOTTOM BRACKET ASSEMBLY

FLYWHEEL AND HUB ASSEMBLY

CRANKS

PEDALS (EXCLUDED BINDING SYSTEMS AND STRAPS)

INSERT SLEEVES FOR HANDLE BAR AND SEAT POST

BOWDEN CABLES (BRAKE ADJUSTMENT)

BRAKE SYSTEM

GAS SPRING

LEVELING FEET

SHROUD AND TOP COVERS

6 MONTHS:

SADDLE CONSTRUCTION (EXCLUDED STITCHING AND SADDLE SURFACE)

THE FOLLOWING WEAR ITEMS ARE EXCLUDED FROM WARRANTY:

Pedal straps, pedal binding systems, saddle surface.

CORPORATE HEADQUARTERS

Columbia Centre III, 9525 West Bryn Mawr Avenue, Rosemont, Illinois 60018 • U.S.A.
847.288.3300 • FAX: 847.288.3703 • Service phone number: 800.351.3737 (toll-free within U.S.A., Canada)
Global Website: www.lifefitness.com

AMERICAS

North America
Life Fitness, Inc. Columbia Centre III
9525 West Bryn Mawr Avenue, Rosemont, IL 60018 U.S.A.
Telephone: (847) 288 3300
Service Email: customersupport@lifefitness.com
Sales/Marketing Email: commercialsales@lifefitness.com

Brazil

Life Fitness Brasil
Av. Reboucas, 2315 Pinheiros,
Sao Paulo, SP 05401-300 BRAZIL
SAC: 0800 773 8282 option 2
Telephone: +55 (11) 3095 5200
Service Email: suportebr@lifefitness.com
Sales/Marketing Email: vendasbr@lifefitness.com

Latin America and Caribbean*

Life Fitness, Inc. Columbia Centre III
9525 West Bryn Mawr Avenue Rosemont, IL 60018 U.S.A.
Telephone: (847) 288 3300
Service Email: customersupport@lifefitness.com
Sales/Marketing Email: commercialsales@lifefitness.com

EUROPE, MIDDLE EAST, and AFRICA (EMEA)

Netherlands and Luxembourg
Life Fitness Atlantic BV
Bijdorplein 25-31, 2992 LB Barendrecht
THE NETHERLANDS
Telephone: (+31) 180 646 666
Service Email: service.benelux@lifefitness.com
Sales/Marketing Email: marketing.benelux@lifefitness.com

United Kingdom

Life Fitness UK LTD
Queen Adelaide, Ely, Cambs, CB7 4UB
Telephone: General Office (+44) 1353.666017
Customer Support (+44) 1353.665507
Service Email: uk.support@lifefitness.com
Sales/Marketing Email: life@lifefitness.com

Germany, Austria, and Switzerland

Life Fitness Europe GMBH
Neuhofweg 9, 85716 Unterschleisheim
GERMANY
Telephone:
+49 (0) 89 / 31775166 Germany
+43 (0) 1 / 6157198 Austria
+41 (0) 848 / 000901 Switzerland
Service Email: kundendienst@lifefitness.com
Sales/Marketing Email: vertrieb@lifefitness.com

Spain

Life Fitness IBERIA
C/Frederic Mompou 5, 1o1a
08960 Sant Just Desvern Barcelona
Spain
Telephone: (+34) 93.672.4660
Service Email: servicio.tecnico@lifefitness.com
Sales/Marketing Email: info.iberia@lifefitness.com

Belgium

Life Fitness Benelux NV
Parc Industriel de Petit-Rechain, 4800 Verviers
Belgium
Telephone: (+32) 87 300 942
Service Email: servicio.benelux@lifefitness.com
Sales/Marketing Email: marketing.benelux@lifefitness.com

All Other EMEA Countries and Distributor Business EMEA*

Bijdorplein 25-31, 2992 LB Barendrecht
THE NETHERLANDS
Telephone: (+31) 180 646 644
Service Email: EMEAServiceSupport@lifefitness.com

ASIA PACIFIC (AP)

Japan
Life Fitness Japan, Ltd
4-17-33 Minami Aoyama 1F/B1F, Minato-ku - Tokyo 107-0062
Japan
Telephone: (+81) 0120.114.482
Fax: (+81) 03-5770-5059
Service Email: service.lfj@lifefitness.com
Sales/Marketing Email: sales@lifefitnessjapan.com

Hong Kong

Life Fitness Asia Pacific LTD
32/F, Global Trade Square
21 Wong Chuk Hang Road
Hong Kong
Telephone: (+852) 2575.6262
Service Email: Service.HK@lifefitness.com
Sales/Marketing Email: hongkong.sales@lifefitness.com

All Other Asia Pacific countries and distributor business Asia Pacific*

32/F, Global Trade Square
21 Wong Chuk Hang Road
Hong Kong
Telephone: (+852) 2575.6262
Fax: (+852) 2575.6894
Service Email: Service.AP@lifefitness.com
Sales/Marketing Email: Marketing.HK.Asia@lifefitness.com

*Also check www.lifefitness.com for local representation or distributor/dealer

CAUTION.

READ ALL PRECAUTIONS AND INSTRUCTIONS IN THIS MANUAL BEFORE YOU BEGIN USING THIS EQUIPMENT. PLEASE KEEP THIS MANUAL FOR FUTURE REFERENCE. IMPROPER ASSEMBLY, SET UP, USE OR MAINTENANCE MAY VOID THE WARRANTY.



EMAIL: INFO@INDOORCYCLING.COM
WEBSITE: WWW.INDOORCYCLING.COM

© 2023 Cy-Tech GmbH

Manufactured by: Cy-Tech GmbH
Happurger Str. 86 90482 Nuremberg Germany