



USER MANUAL V.02



TABLE OF CONTENTS.

P.3-5

1. INTRODUCTION

- 1.1 Important Precautions P.3
- 1.2 Technical Specifications P.4
- 1.3 Basic Maintenance P.5

P.6-13

2. INSTALLATION

- 2.1 Introduction P.6
- 2.2 Assembly Parts and Tools P.7
- 2.3 Assembly - free standing P.8
- 2.4 Assembly - wall mounted P.10
- 2.5 Power on the Myride® system P.12
- 2.6 Service Parts P.13

P.17-28

3. OPERATION

- 3.1 Using your Myride system P.17
- 3.2 Setup mode for Administrators P.18
- 3.3 MyTV setup and functions (optional) P.19
- 3.4 MyMusic functions P.23
- 3.5 Learn the moves P.25
- 3.6 Update P.26
- 3.7 Exchange Configuration P.28

P.29

4. WARRANTY TERMS

The production batch number is found on the backside of the MyRide Wave stand located next to the connectivity plate. P.29

QUESTIONS?

At Indoorcycling Group we are committed to provide complete customer satisfaction. If you have any questions, please contact your local distributor or refer to our web-site www.indoorcycling.com

1. INTRODUCTION.

1.1 IMPORTANT PRECAUTIONS

1. It is the sole responsibility of the owner/operator and his staff to ensure that all users of the indoor cycle are informed of all warnings and precautions by an authorized trainer or instructor prior to using the Myride product.
2. Any indoor cycle used in conjunction with the Myride system must be operated and maintained in accordance with its owners manual.
3. The Myride system is intended for indoor use only. Do not use in areas with poor insulation, excessive dust or moisture (for example, near a swimming pool).
4. Place the Myride system on a level surface. To protect the floor or carpet from damage, place a mat beneath the equipment. Be sure there is sufficient space around the Myride system and indoor cycling bike for a user to mount, dismount and operate the equipment safely.
5. Regularly inspect all parts of the Myride hardware. Please replace defective parts immediately and do not use the equipment until repairs are carried out. Only use original parts from the manufacturer.
6. Children under the age of 16 should only use the Myride system with parental approval and under supervision of a specially trained instructor.
7. Always wear appropriate athletic clothes and shoes while operating the indoor cycle. Do not wear loose clothes that could become caught on the indoor cycle. Keep laces secured and out of the way of moving parts.
8. Before using the indoor cycle, make sure that you are familiar with the setup/operation of the indoor cycle. If not, refer to the respective owner's manual of the bike or ask a trainer.
9. Some indoor cycles do not have an independently moving flywheel (wheel); the pedals will continue to move together with the flywheel until the flywheel stops.
10. If you feel pain or dizziness while using the Myride system, stop immediately, rest and cool down and consult a physician.

WARNING!

To reduce the risk of serious injury please read the following important precautions and information before enjoying the Myride personal training experience.

MEDICAL WARNING:

Before beginning any exercise program, consult your physician. This is especially important for persons with pre-existing health problems.

Read all instructions before use. Be aware that incorrect exercise may result in serious injury. The manufacturer assumes no responsibility for personal injury or property damage sustained by or through the use of this product.

1.2 TECHNICAL SPECIFICATIONS.



The exclamation point within a triangle is intended to warn the user of important operating and maintenance instructions.

WARNING: To prevent risk of electric shock or fire, do not allow this system to become wet. Do not expose the Myride system to moist environments, and do not place liquid filled containers on or near the unit.

ATTENTION: To prevent a risk of electric shock, be sure the power plug is fully and correctly inserted into the Myride system and the wall socket.

CAUTION: RISK OF ELECTRIC SHOCK. DO NOT OPEN

High voltages are present within the enclosure. Do not open the monitor or computer housing. There are no user-serviceable parts inside the Myride system. Only trained and qualified service technicians should service the Myride system.

SYSTEM SPECIFICATIONS.

MONITOR	17.3" / 1600 X 900 / 16:9 / 400 NITS / 30W MAX
TOUCH SCREEN	4 WIRE RESISTIVE INDUSTRIAL-GRADE TOUCHSCREEN PANEL
VIDEO CONTENT	1280 X 720P HD
OS	UBUNTU LINUX LIVE SYSTEM
PC	INTEL ATOM, ION2, 500 GB HDD, 2 GB RAM, 35W MAX
POWER	110-220V AC INPUT / 2 X 12V 3.5A DC OUTPUT
TV TUNER	BUILT-IN MINI PCIE CARD (ATSC/NTSC OR DVBT/PAL)
WORKING TEMPERATURE	40° F-110° F (5° C - 45° C)
CONNECTIONS	USB 2.0, RJ45 LAN, TV COAX OPTIONAL (F-CONNECTOR)

CONNECTIONS FOR MYRIDE+ UPDATES

HDMI OUT, 3,5MM STEREO AUDIO OUT

1.3 BASIC MAINTENANCE.

ENVIRONMENT:

Keep the Myride system between 30% and 70% humidity. Low humidity can cause gaskets to dry out; high humidity may cause condensation inside the unit. Operating temperatures should not exceed 110° or dip below 40° Fahrenheit. Spikes or dips in voltage may damage the Myride system. If your power is subject to fluctuations, prevent damage to the Myride system with a surge protector.

CLEANING:

The LCD and touchscreen panel is delicate. Clean only when necessary with a soft, damp cloth. If necessary, moisten the cloth with a diluted, mild detergent. Never use liquids on the touch screen, which can leak into the wave stand and cause electrical problems.

The wave stand itself may require occasional dusting. Do not use cleaning liquids on the wave stand, as they can leak into the stand and damage electronics. Avoid harsh chemicals or abrasives which may damage the coating on the surface of the stand.

SOFTWARE:

To take advantage of new features and bug fixes, update the software on the Myride system occasionally. You can check for new software at www.indoorcycling.com

To update the software, download the update file onto an empty USB stick (FAT32 file format), and plug the USB stick into the Myride. Turn on the Myride and follow the on-screen instructions. When the update is finished, the Myride will reboot, signaling that it is safe to remove the USB stick. (If not removed soon after the reboot, the update process may happen again -- avoid this by promptly removing the USB stick when the Myride reboots.) Check for updates at least semi-annually.

HARDWARE:

Heavy use may work some fasteners loose. As part of your quarterly maintenance, please verify that all bolts and screws are secure in the Myride wave stand.

TROUBLE SHOOTING:

Should any unexpected problems arise, please consult the troubleshooting guide at www.indoorcycling.com. If problems persist, contact your service representative.

2. INSTALLATION.

2.1 INTRODUCTION.

THE MYRIDE SYSTEM

The Myride system is a touchscreen media console for use as an exercise aid. The system consists of an industrial computer and touchscreen, housed in a sheet metal wave stand. The computer and touchscreen are fully connected and configured at the factory, but the wave stand requires some assembly on-site. Depending on mounting and other options, setup may take from 30 minutes to slightly over one hour.

SETUP REQUIREMENTS

Tools and parts: All tools and parts necessary for assembling the wave stand are included in the original shipping box. Wall mounting the Myride system will require additional hardware and tools.

CUSTOMER SUPPORT

For the most up-to-date customer support, please visit the website at www.indoorcycling.com. Basic maintenance and support questions are addressed in this manual. If your problem is not answered by these resources, or if your Myride system requires service, please contact your distributor.

INSTALLATION NOTES:

Myride® is a product for professional and / or commercial use. Such training equipment is intended for use in training areas of organizations such as fitness clubs or sport associations where access and control is regulated and the legal responsibility for use lies with such club or association.

FOOT PRINT OF MYRIDE SYSTEM:	86 X 56 CM / 34 X 22 INCH
WEIGHT OF MYRIDE SYSTEM:	42KG / 92.5 LBS
HEIGHT OF MYRIDE SYSTEM:	150CM
FOOT PRINT OF MYRIDE + BIKE:	APPROX. 200 X 65 CM / 79 X 26 INCH
WEIGHT OF MYRIDE + BIKE:	APPROX.100 KG / 220 LB

2.2 ASSEMBLY PARTS & TOOLS.

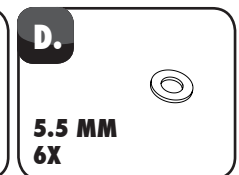
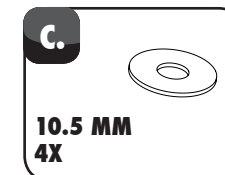
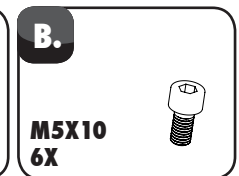
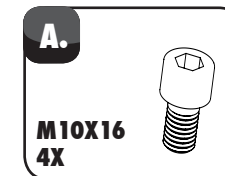
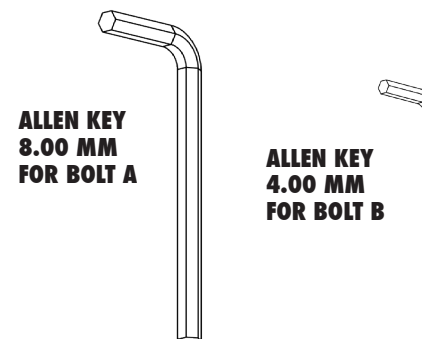
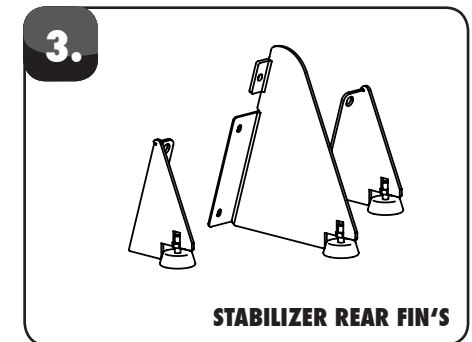
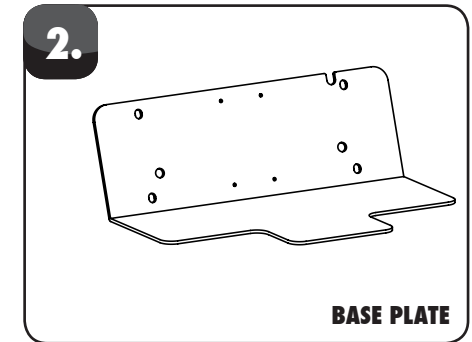
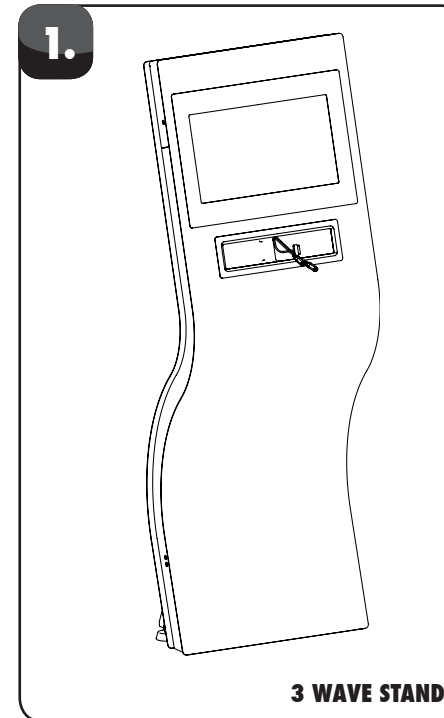

2.3 ASSEMBLY - FREE STANDING

1: REMOVE THE WAVE STAND FROM THE PACKAGING

The Wave stand is very heavy! It requires at least two people to remove the stand from the packaging. Make sure you have a firm grip, and avoid holding the edges (which may bend). Please verify when unpacking that all of the required parts are included with the stand. Place the wave stand on the side for easier assembly.

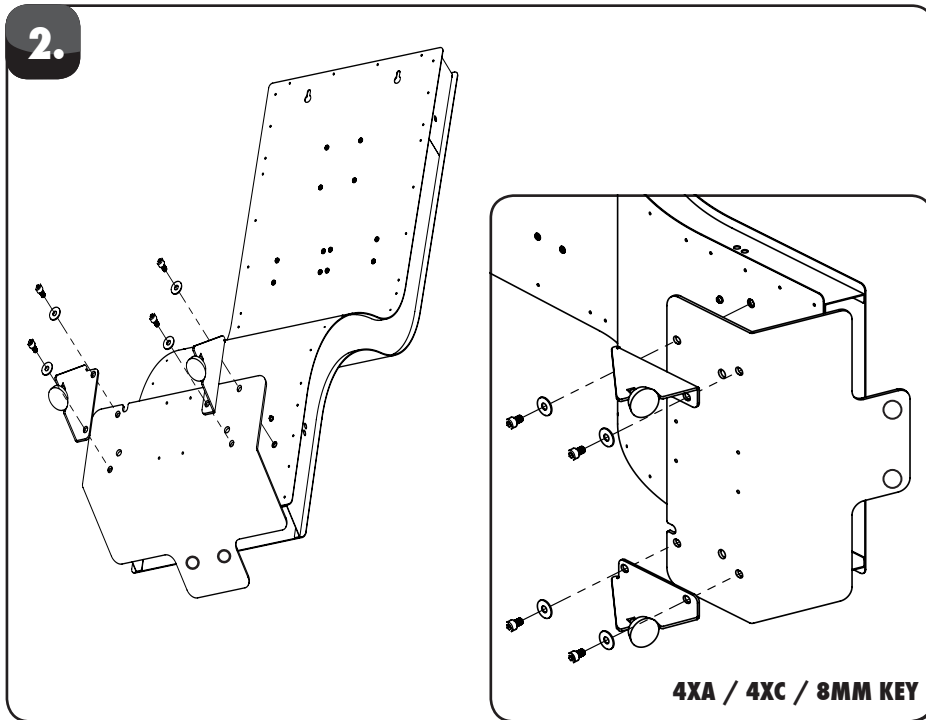

2: ATTACH THE BOTTOM PLATE AND SIDE FINNS

Place the Wave stand on its side for assembly (see illustration). Place the base plate on the stand and secure the two small fins to the rear by bolting through the base plate and into the screw posts at the bottom of the stand. Before tightening the bolts, tap or push the base plate to ensure it is seated firmly against the bottom of the wave stand.

3: ATTACH CENTER FIN AND RUBBER FEET

Place the large center fin over the bolt holes in the wave stand and secure using six M5 bolts with washers. Affix the four adhesive rubber pads to the base of the wave stand as shown in the illustration.

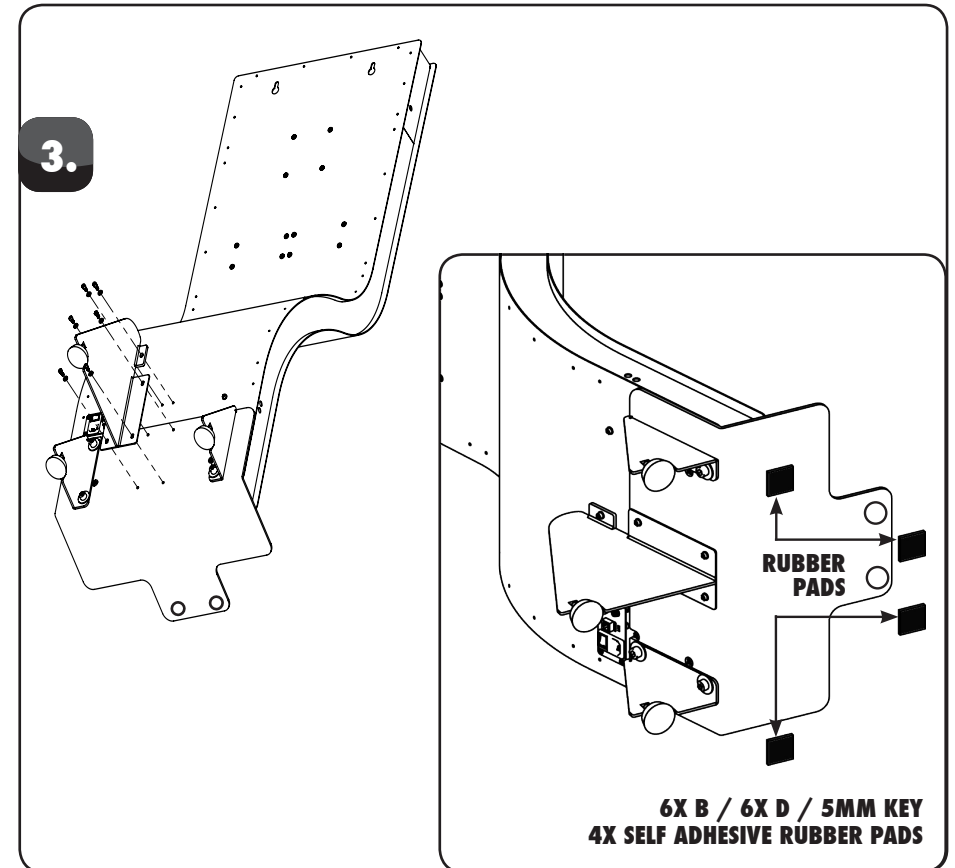

4: MOVE THE MYRIDE SYSTEM INTO POSITION

With at least two people, pick the Myride system up and move to its proper location. Use a firm grip; do not slide or tilt the stand, as the weight of the unit may bend the metal frame. To prevent the Myride system from tipping over, manufacturer recommends to bolt the unit to the floor using the holes in the floor plate. Make sure sufficient bolts and anchors are being used.

2.4 ASSEMBLY - WALL MOUNTED

1: REMOVE THE WAVE STAND FROM THE PACKAGING

The wave stand is very heavy! It requires at least two people to remove the stand from the packaging. Make sure you have a firm grip, and avoid holding the edges (which may bend). Please verify when unpacking that all of the required parts are included with the stand.

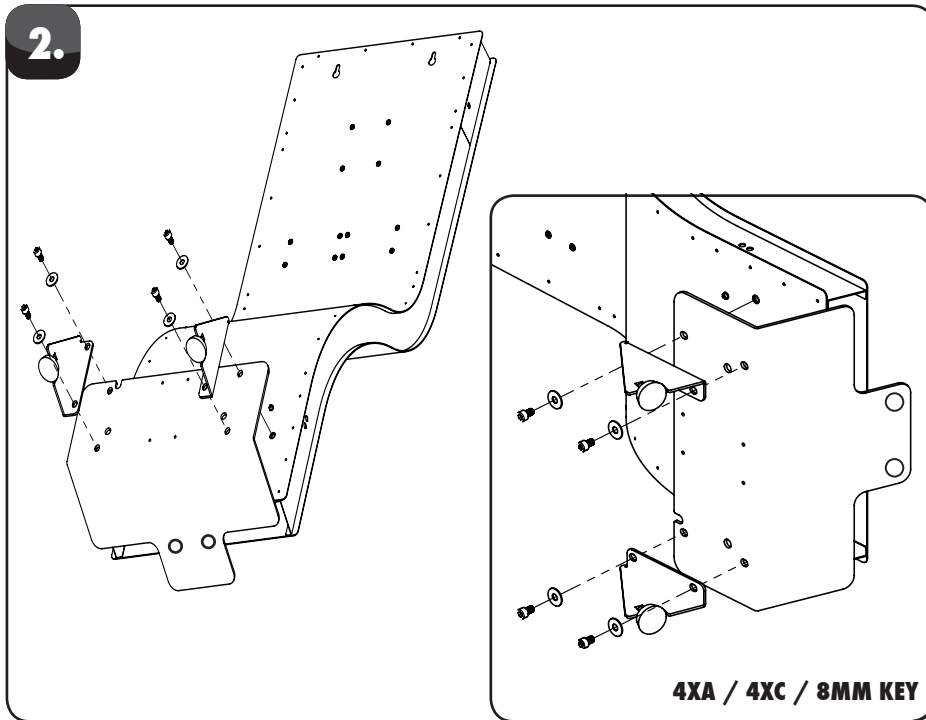

2: ATTACH THE SIDE FINIS

Place the wave stand on its side. Secure the two small fins to the rear of the wave stand, rubber foot side down, by bolting into the posts. When wall mounted, the Myride system does not use the base plate or the center fin.

3: PREPARE THE WALL ANCHORS

Measure up 55" (1400 mm) from the floor. Insert two wall anchors 10.5" (265 mm) apart, following the anchor manufacturer's directions. Note: the anchor must be rated to support at least 100 lbs. Be sure the wall itself can support the weight of the stand!

3.

IMPORTANT! The weight of the Myride system of 92.5 lbs requires the use of proper wall mounting fixtures supporting the weight of the system. If you are unsure what fixtures are suitable, please consult your local professional. Warranty may void in case of improper mounting.

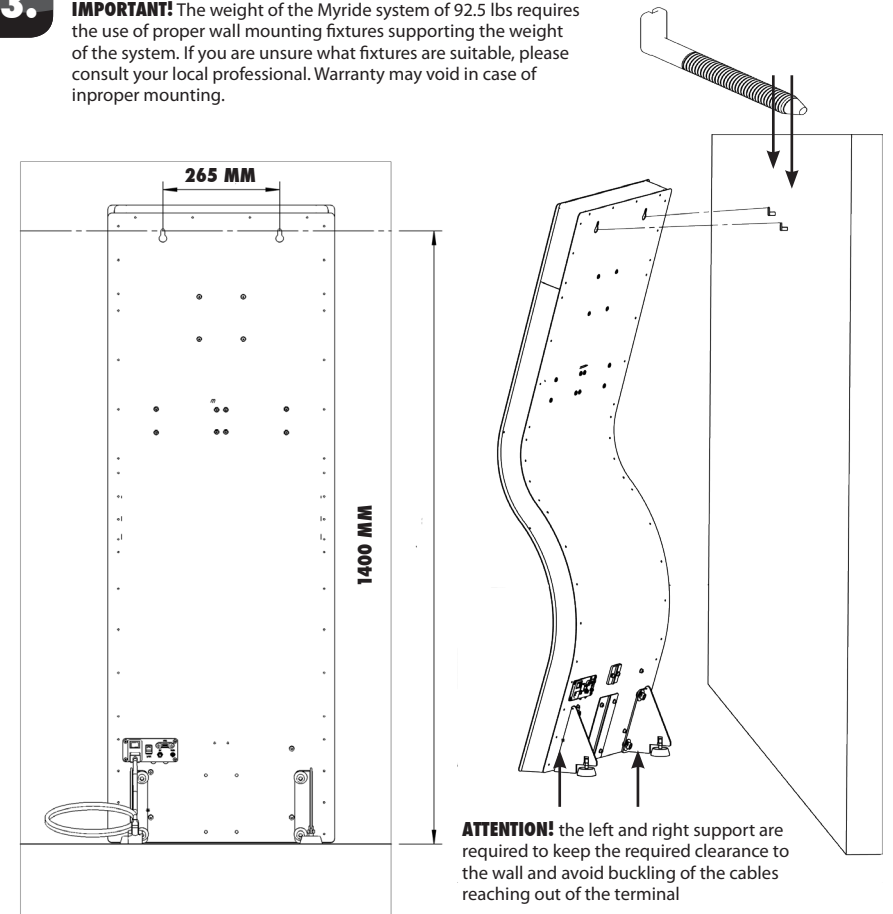

4: MOUNT THE MYRIDE TO THE WALL ANCHORS

With at least two people, lift the Myride system onto the wall anchors.

2.5 POWER ON THE MYRIDE SYSTEM

Once you have finished the installation of the Myride system, plug in the power cable and turn the power switch to on (I). The Myride system will take a moment to boot up.

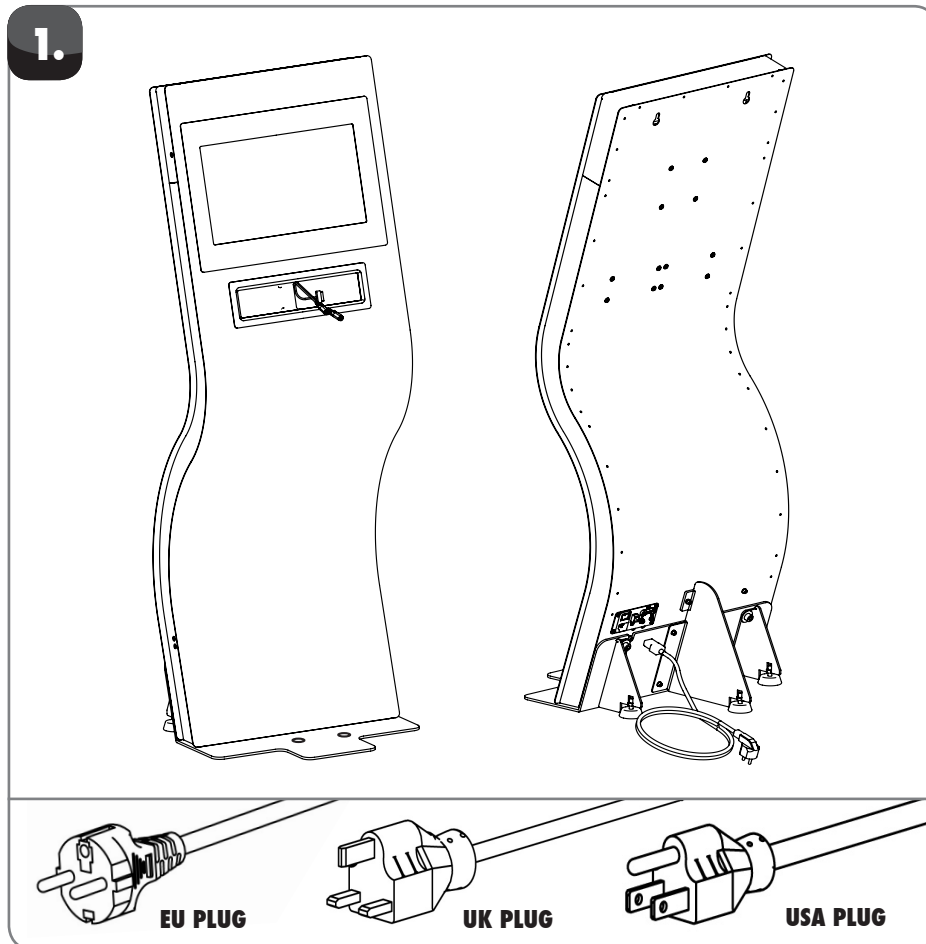

ATTENTION!

Please use the AC extension cable required for the electrical system in your country. Consult a professional electrician if you are unsure how to connect the Myride system to your in-house electrical circuit.

Version 2.0 Copyright by Indoorcycling Group GmbH 2011 | www.indoorcycling.com ENG 12

2.6 SERVICE PARTS



ART. NO: 500 033
Mini PC DVB-T/PAL
TV Tuner (optional)
Made for iPod/iPhone



ART. NO: 500 032
Mini PC ATSC/NTSC
TV Tuner/
Made for iPod/iPhone

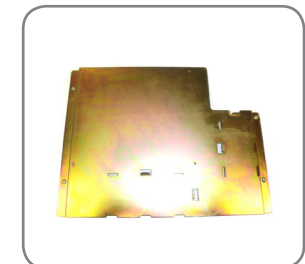

ART. NO: 500 095
Mounting plate for PC
Zinc coated

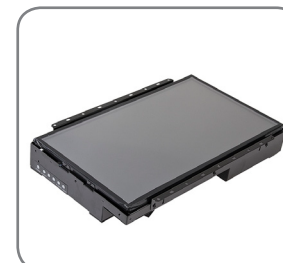

ART. NO: 500 020
Touchscreen monitor
17,3"

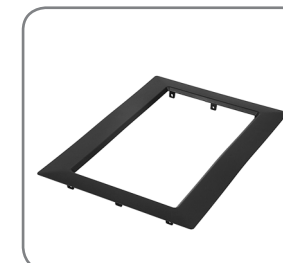

ART. NO: 500 021
Bezel for 17,3" TS monitor
Black color; incl. rubber gasket



ART. NO: 500 080
PSU 110/220V
2x 12V/2,5 A
Power supply for
monitor and PC

2.6 SERVICE PARTS

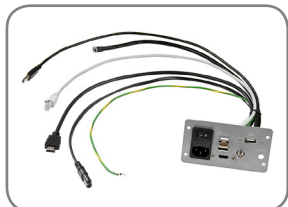

ART. NO: 500 092
Terminal plate for external connections incl. cables (USB, RJ45-LAN, HDMI, TV, Audio, power & ground cable)



ART. NO: 500 094
Internal L-bracket incl. cable harness (2x USB A; 1x audio extension to PC and terminal plate)



ART. NO: 500 081
Fuse (5 Ampere) for power switch



ART. NO: 500 070
Made for iPod 30 pin connection cable; 70 cm; L-bracket > basket



ART. NO: 500 071
4 pin Audio twin socket „Y“ extension cable; 110 cm; L-bracket > basket



ART. NO: 500 074
USB cable male/female; 130 cm; PC > L-bracket



ART. NO: 500 091
Storage basket for iPod/iPhone incl. mounting material

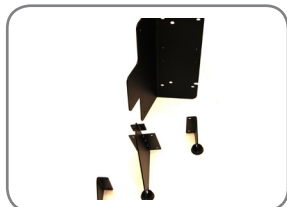

ART. NO: 500 093
Floor plate and 3 pcs. fins (backside) incl. mounting material

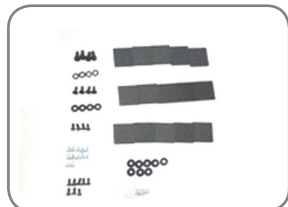

ART. NO: 500 099
Service kit incl. screws and foam pads



ART. NO: 500 075
USB cable male/female; 60 cm; PC > terminal plate



ART. NO: 500 076
RJ-45 LAN cable; 60 cm; PC > connector plate

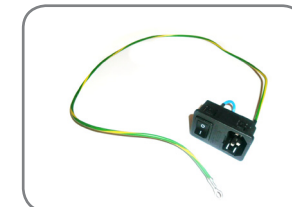

ART. NO: 500 077
AC power switch incl. ground cable; 60 cm; power switch > PC mounting plate



ART. NO: 02 11 05B MYR
Leveling feet



ART. NO: 500 078
HDMI cable male/female; 60 cm; PC > terminal plate



ART. NO: 500 079
internal power cable male 60 cm; power switch > power supply unit



ART. NO: 500 050
VGA cable male/male 150 cm; PC > monitor

2.6 SERVICE PARTS



ART. NO: 500 051
USB cable male/male; 150 cm;
PC > monitor



ART. NO: 500 052
TV cable male/male; 60 cm;
PC > terminal plate



ART. NO: 500 053
Audio cable extension
internal Y-splitter
130cm/60cm
L-bracket/terminal plate > PC



ART. NO: 400 209
UK extension cable



ART. NO: 400 210
USA extension cable



ART. NO: 400 211
EU extension cable

3. OPERATION

3.1 USING YOUR MYRIDE SYSTEM

PLEASE REGISTER YOUR MYRIDE SYSTEM BEFORE YOU START ANY OPERATION!

Contact your distributor if you need any support during this process.
You will have a 30 day trial period until the registration process needs to be completed.

USING THE TOUCHSCREEN

The Myride features a 17.3" single-touch industrial touchscreen. The touchscreen functions best with a firm touch from the fingertip – no stylus is required, and touching the screen with more than one finger at a time will not work.



Most icons on the Myride are touch buttons – a single press will activate the control. Lists, such as a playlist for a custom-built workout, can be scrolled by touching the screen with your finger and dragging across the surface of the touchscreen. The Television channel list (MyTV) should be scrolled by touching near the channel listing and dragging.

THE HOME SCREEN

The Myride experience begins at the home screen. Touching the icons on the home screen will launch different entertainment and coaching options. The coached workouts are the MyRide studio workout and MySportif outdoor coaching. For non-instructed workout entertainment, the Myride system features MyScape and optional television (MyTV). By using the MyMusic function you can connect your own media device (Made for iPod/iPhone). You can always return to the homescreen by touching the "home" icon in the lower left corner of the screen (it will appear in the upper left on the Administration Screen).

3.2 SETUP MODE FOR ADMINISTRATORS

Starting from the home screen, enter the Administration Screen to make changes to the configuration of your Myride. It is not password protected, but it is hidden from view. To activate it, touch the ICG logo in the lower-right corner of the screen (1), then touch the 'Myride v3.0' text in the upper-left corner (2) within 1.5-2 seconds. This automatically launches the Administration Screen (picture below). To return to the home screen, touch the "home" icon in the upper left corner. You can use the Administration Screen to make changes to your system.

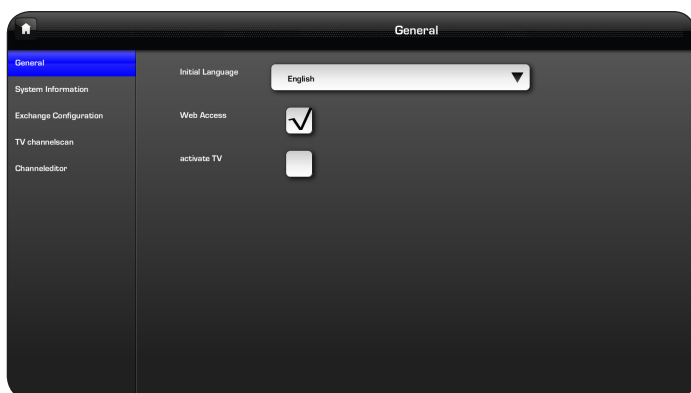

3.3 MYTV SETUP AND FUNCTIONS

(OPTIONAL)

The Myride has the ability to decode analog and digital television signals. Some television signals will not be appropriate, such as encrypted channels (which would require a cable or satellite decoder), but most cable boxes and all over-air and in-club television signals will work.

1: PHYSICALLY CONNECT THE TELEVISION TO THE MYRIDE

Using an F-connector coaxial cable (not included), connect the Myride to your television source.

2: ENABLE TELEVISION IN THE ADMINISTRATION MENU

Navigate to the administration menu by touching the icon in the lower-right of the screen, then touching the 'Myride v3.0' text in the upper-left corner of the screen. On the 'General' tab, touch the checkbox for TV. (Unchecking this box later will disable TV on the home screen.)

3: CHOOSE YOUR TELEVISION STANDARD

The Myride can decode many different types of television signals. It is important you know what kind of television signal you are providing to the Myride. If you are unsure of your television signal, contact your television service provider.

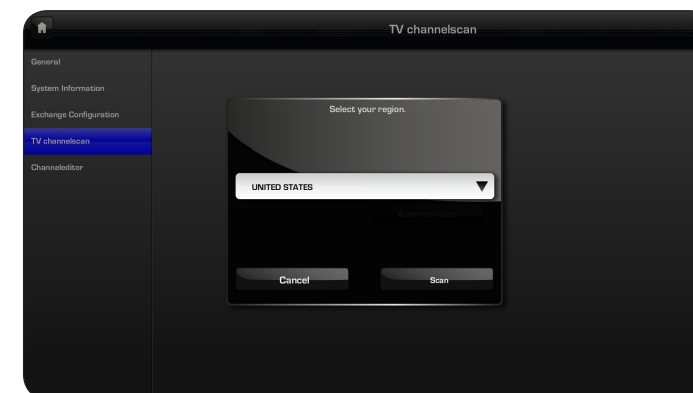

In the administration menu, choose 'TV Channelscan' from the left pane. On the Channelscan screen, choose your region from the top dropdown menu. This will highlight what types of television signals are available in your country. For analog sources (like in-club distributed TV), choose NTSC or PAL. For digital sources, choose the appropriate source: over-air if the Myride is connected directly to an antenna, or terrestrial/cable if it is connected to a decoder or box (or if your club has digital television distribution -- this is rare).

4: PERFORM A CHANNELSCAN

In order for the Myride system to list and allow to change TV channels successfully, it must scan the incoming television signal. This process might take a while.

Once you have chosen the signal type, a 'scan' button will appear next to its checkbox. Touch the scan button to start a channelscan. (This process can take up to thirty minutes.) During this time, the Myride is detecting available channels and adding them to the TV menu. While scanning, the Myride will display a series of technical messages. When it is finished, the message 'channelscan finished' will appear at the end of the list. You can now navigate away from the message by touching the 'cancel' button (the results have already been saved).

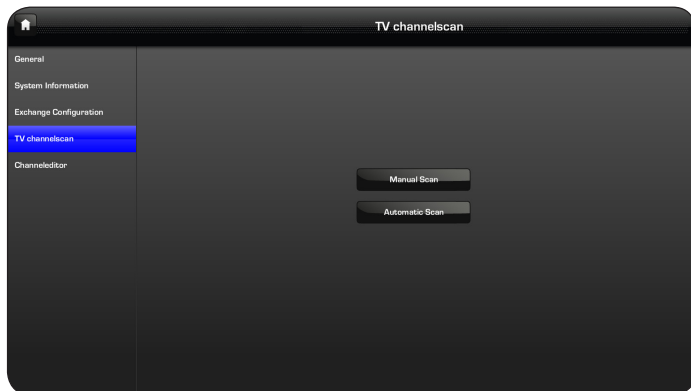

5: EDITING THE CHANNEL LIST

Once the channel scan has finished, you can edit the list. Choose 'TV Channel Editor' in the left pane to bring up the channel editor. If the channelscan was successful, a list of detected channels will appear in the next pane over (picture below). By selecting each channel in that pane, you can choose to activate or inactivate individual channels.

If the channel list is empty, please verify that you selected and scanned the correct signal type. Most clubs' in-house television systems are analog (NTSC or PAL), while cable or over-air television is typically digital (ATSC or DVB). If you are unsure, contact your television provider or try scanning different television signal types.

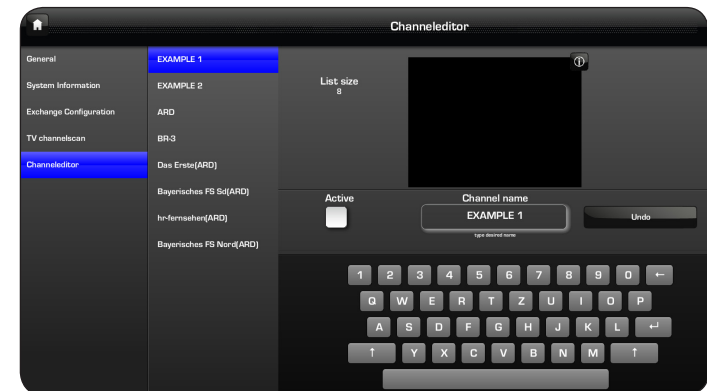

Note: some cable or satellite television stations may be encrypted (for example, premium digital cable signals). They will be detected by the channelscan, but will appear as static and should be removed from the channel list in the channel editor.

6: USING MYTV

From the home screen, touching the 'MyTV' button will launch the television. To change channels, you can touch the MyTV channel button or simply touch the middle of the screen to call up the channel list.

Touch the channel listing to change channels, and touch-and-drag to scroll the channel listings. Touching the TV screen away from the channel list closes the channel listing panel.

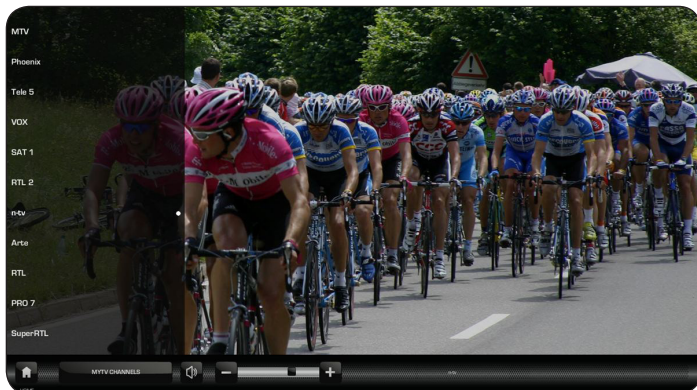

3.4 MYMUSIC FUNCTIONS

The Myride system is „Made for iPod/iPhone“. Please connect your media device by using the 30 pin connector cable at the front of the device.

ENTERING THE MYMUSIC MODE

You can control your media device at anytime during a MySportif or MyScape workouts by pressing the Music button in the navigation bar at the bottom of the screen (1) or by pressing the MyMusic button on the home screen (2).



MUSIC BUTTON

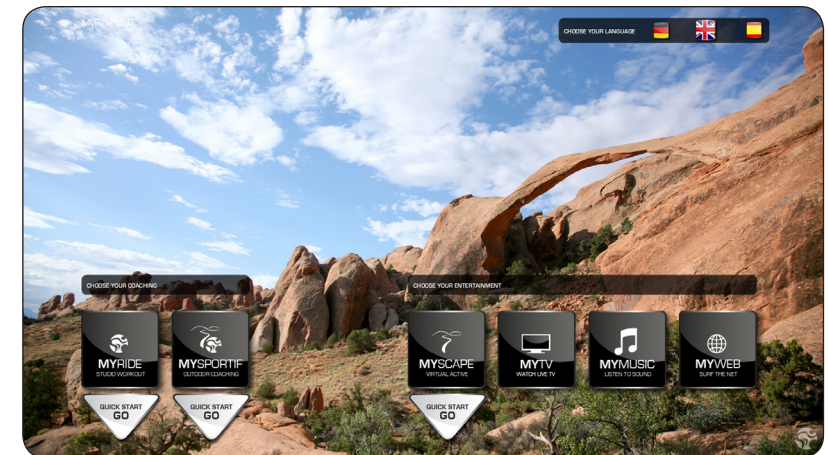

MUSIC BUTTON

2.

Attention: You can't listen to your own music during a MyRide workout or while watching TV. All MyRide workouts have their own music built-in.

3.4 MYMUSIC FUNCTIONS

Within the MyMusic mode you can control the playback of either built-in music (internal jukebox) or of your personal music on your media device.

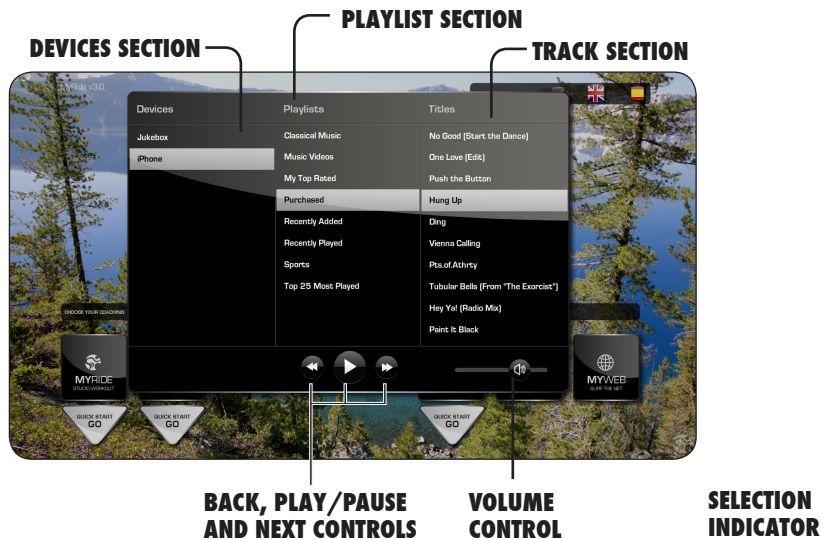

DEVICES SECTION	LISTS ALL OF YOUR CONNECTED DEVICES
PLAYLIST SECTION	LISTS THE PLAYLISTS OF THE SELECTED DEVICE
TRACK SECTION	LISTS ALL TRACKS OF THE SELECTED PLAYLIST
SELECTION INDICATOR	HIGHLIGHTS THE SELECTED ITEM
BACK PLAY/PAUSE NEXT CONTROLS	GIVE YOU THE ABILITY TO CONTROL YOUR IPOD
VOLUME CONTROL	CONTROLS THE VOLUME AUF THE MYRIDE SYSTEM

3.5 LEARN THE MOVES

WARNING

This product is intended to motivate fit, healthy exercisers.

This product and coaching are not intended to replace the services of a physician, nor does it constitute medical advice. This product is not intended to diagnose, treat, or cure any medical condition. Any actions you take in the course of using this product are entirely at your own discretion; please use good judgment. You should consult with your physician about the appropriateness of any workout for your individual health, and before starting a new exercise regimen.

Please watch the "learn the moves" instructions to learn about the bike setup, riding positions, energy zones or how to built your workout. To enter the "learn the moves" tutorials, please press MyRide or MySportif button on the home screen (1), then select "learn the moves" by pressing the button. The tutorial will start automatically (2).

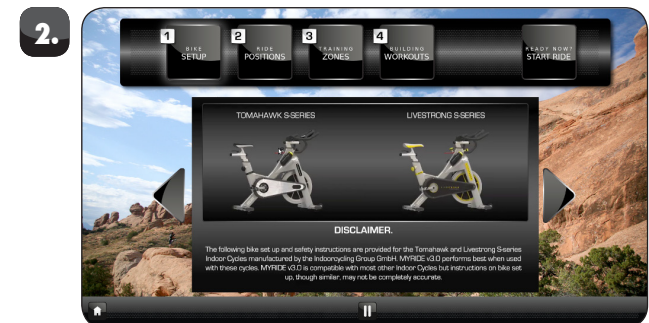

3.6 UPDATE

To see the latest software version, installed on your Myride system, enter the Administration Screen. Press System Information to show all individual information of your Myride system, including the current SW Version.

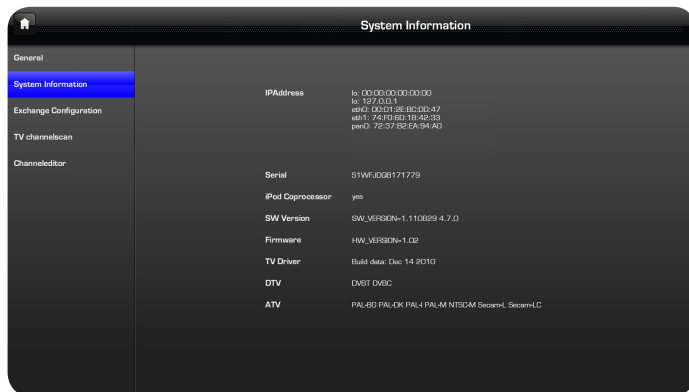

Software updates can be downloaded from support website www.indoorcycling.com Please only use an empty, FAT 32 formatted, USB Stick to store the update.

FOLLOWING STEPS MUST BE DONE TO INSTALL THE UPDATE SOFTWARE ON YOUR MYRIDE SYSTEM:

STEP 1:

Put the USB Stick (with latest software update) into the USB slot.



STEP 2:

The system will ask, if you want to install the update. Press "Installing System Update".

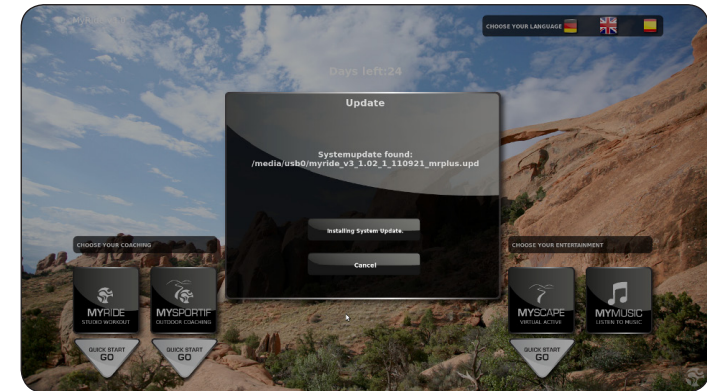

STEP 3:

After the update is finished, the Myride system will reboot again. Before that, the Myride system invites you to remove the USB stick.

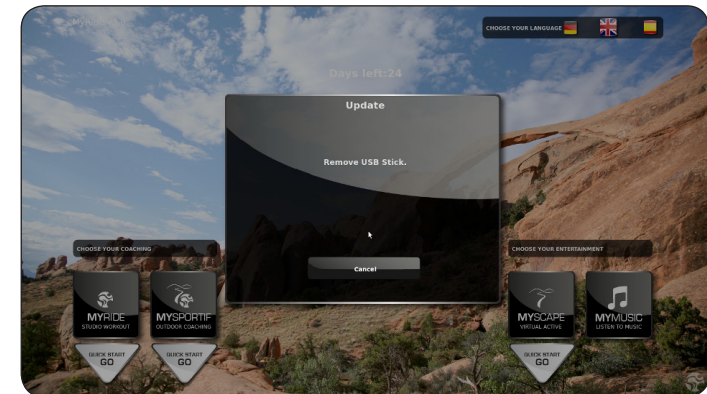

3.7 EXCHANGE CONFIGURATION

It is possible to exchange the configuration from one Myride system to another.

EXPORT CONFIGURATION

Put an empty, FAT 32 formatted, USB stick into the USB slot of the Myride system. Enter the Administrator Screen and select Exchange Configuration.

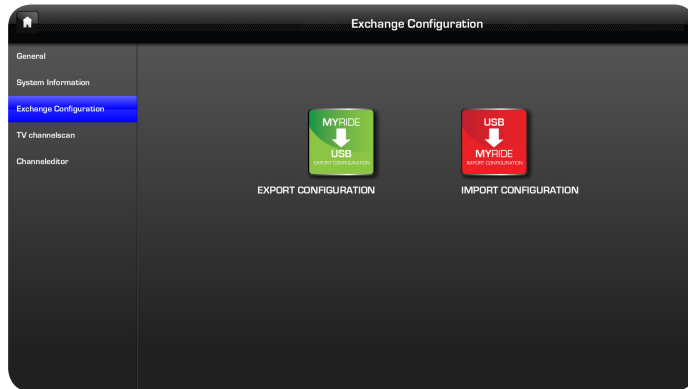

Press Export Configuration and wait, till the configuration is exported on the USB stick. Remove the USB stick.

IMPORT CONFIGURATION

Put the USB stick with the exported configuration of a Myride system into the USB slot of another system, where you want to add the same configuration. Enter the Administrator Screen and select Exchange Configuration. Press Import Configuration and wait, till the configuration is imported on the Myride system. Remove the USB stick.

4. WARRANTY TERMS

Indoorcycling Group GmbH warrants that all new equipment will be free of manufacturing defects in workmanship and materials, becoming effective on the date of the original registration of the Myride system on www.indoorcycling.com. Parts and components repaired or replaced under the terms of warranty will be warranted for the remainder of the original warranty period only. Warranty may vary by region or country.

Please contact Indoorcycling Group GmbH by email info@indoorcycling.com to obtain detailed information on applicable warranty terms and conditions.

Please note that warranty does not cover for damages caused by inappropriate use of the Myride product and any negligent act by the consumer. Manufacturer states that the product was thoroughly tested and found free of failure prior to shipping.

IMPORTANT!

Manufacturer requires the proper registration of the product on its dedicated support website www.indoorcycling.com to uphold warranty obligations.

LIMITED WARRANTY ON MYRIDE SYSTEM

5 YEARS WARRANTY:	MYRIDE METAL WAVE STAND
2 YEARS WARRANTY:	<ul style="list-style-type: none"> * MONITOR BEZEL (ART.: 500 021) * BASKET (ART.: 500 091) * INTERNAL MONITOR CABLE ROUTING (VGA, USB) * EXTERNAL CABLE CONNECTION TERMINAL INCL. HARD WIRES FROM TERMINAL TO PC (ART.: 500 092)
1 YEAR WARRANTY:	<ul style="list-style-type: none"> * MINI PC INCL. HDD, RAM, TV HYBRID TUNER (ART.: 500 032 ATSC/NTSC & ART.: 500 033 DVB-T/PAL) * 17,3" SINGLE TOUCH MONITOR (ART.: 500 020) * INTERNAL POWER SUPPLY UNIT (ART.:500 080)

The following items are considered wear items excluded from warranty:

- * Audio twin socket, Y" extension cable (Art.: 500 571)
- * Media device connection cable; USB > 30pin (Art.: 500 070)

CAUTION.

Read all precautions and instructions in this manual before you begin using this equipment. Please keep this manual for future reference. Improper assembly, set up, use or maintenance may void the warranty.

The Myride® content is licensed to be used exclusively with an exercise bike as a personal training device. No other license is conveyed, expressed or implied.



EMAIL: INFO@INDOORCYCLING.COM
WEBSITE: WWW.INDOORCYCLING.COM

